

Stratos

Spreaders 4 – 12 m³



www.aebi-schmidt.com

 **schmidt**
a brand of aebi schmidt

Stratos spreaders

Stratos spreaders by Schmidt:

Maximum versatility combined with a high degree of economic efficiency!

Employed on all streets, roads and motorways throughout the world: spreaders by Schmidt! The great success of these products reflects our excellent reputation for manufacturing products with outstanding value for money. Owing to intensive dialogue with our customers, we regularly develop innovations which set new standards for the entire sector: The name Schmidt stands for forward-looking quality which pays off for you day-by-day.

The concept of the Stratos:

Thinking holistically, developing with foresight, working sustainably.

Stratos spreaders are counted among the best of their kind on a worldwide scale. The reason for this is a holistic product concept, incorporating and perfectly synchronising all essential details such as flexible modular design, accurate distribution systems, intelligent control systems as well as highly effective corrosion protection. This results in unique economic performance, which is of growing significance, especially in times of increasingly tighter budgets. Invest in maximum product safety!

From “S” to “XXL”:

Every Stratos means superior de-icing on all streets and roads.

Stratos spreaders are available in various sizes and are compatible with most tractors and carrier vehicles. The range of possible applications extends from the private to the municipal area – efficient de-icing operations are guaranteed on streets and squares just as much as on dual carriageways and motorways. A forward-looking technology concept is applied dependant on the field of application and the weather conditions: With Stratos, you are optimally equipped for any de-icing operation.



New Generation

4–12 m³



A new generation

Intelligence meets efficiency

The new generation of Stratos spreaders is based on many years of worldwide experience and takes any spreading operation to an entirely new level. Owing to their innovative, modular design, the spreaders can be adapted to your individual applications and permit maximum flexibility in resource planning. The intuitive handling and the convincing performance of the new product line makes your work even more intelligent and efficient.

Modular design for individual requirements

The modular design of our spreaders permits individual configurations that are accurately tailored to your tasks and operating conditions. The combination of hopper, conveyor belt or auger system, pre-wet equipment, various distribution systems, drive options, demount systems and control systems offers maximum flexibility.

Long service life at low costs

Whether durable stainless steel or high-quality polyethylene: Our new spreaders employ exclusively high-quality materials. This provides protection for a long service life while reducing maintenance costs. In order to additionally increase their durability, all steel and stainless steel spreaders are blasted and powder-coated.

Environmentally friendly and sustainable

Wherever possible, we use components made of recycled materials. Correspondingly, the polyethylene and metal components of the spreaders can be recycled as well. A sophisticated filter system in the powder-coating plant ensures that residual powder can also be recycled – thus being easy on the environment and your budget. The Stratos's outstanding spreading technology also makes it environmentally friendly and economic to use.

New generation

Intelligence meets efficiency

Reliable application of spreading material

We have further optimised our conveyor belt and belt cleaning system for you, the result being an increased service life, faster servicing and affordable maintenance. Our auger system is equipped with a dosing disc to permit very even spreading material application.

Maximum flexibility during demounting

Always in top form: No matter whether you want to demount completely filled or empty spreaders – the new Stratos can handle both.

Innovation – Optimised spreading disc with kick-back protection

A system that thinks ahead: On contact, the entire distribution system folds away to the back, preventing damage to your spreader. Furthermore, the use of PE and the optimised angle of the outlet considerably improve the spreading material's flow properties. It is also noteworthy that our Premiumplus mixing chamber distribution system is available for all existing spreading width configurations.





We aim for making your work as easy and efficient as possible

The new Schmidt EvolutionLine comprises three innovative operating concepts which, thanks to their modular structure, can be easily adapted to your requirements. Using one of these professional solutions, you can make your work even easier and more efficient.



High-speed servicing and affordable maintenance

The use of stainless steel, composite and PE components and the application of powder-coated materials protect the machine. This protection is sure to pay off in terms of a long service life and low maintenance costs.

Mounting and demount systems

Maximum safety – Mounting and demount systems

The key components of the Stratos systems are designed for maximum safety and stability. Correspondingly, their consistently sturdy design also offers maximum safety during mounting and demounting.

The new Stratos systems are available in two basic variants:

- For demount legs, hooklifts and fix-mounted systems
- Especially for the ro-ro system

Both variants can be demounted with a full hopper and full brine tanks.

The new ro-ro system – Even better and easier to use

The further development of the ro-ro system enabled us to make efficient improvements in trailer operation: The 40-cm increase in clearance permits the use of a trailer or a mobile warning sign. In addition, the small tipping angle and the safety belt offer maximum safety while mounting and demounting.

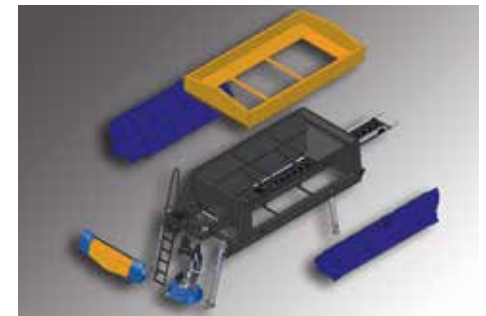

Benefit from:

- Maximum flexibility during demounting: Whether the spreader is full or empty: the new Stratos can handle both. The great variety of mounting and demount systems makes any truck equipped with a Stratos spreader an ideal winter service combination
- Improved ro-ro spreaders: More clearance space and easier handling during trailer operation
- Maximum safety during mounting and demounting: Key components with a consistently sturdy design
- Maximum safety during driving: Independent tests confirm that our anti-skid mats have a frictional value of 0.5 μ at temperatures of up to -20 °C



TIZI 03

Höhe 4,15 m
Breite 4,70 m

TIZI 03



6

17268LV

MAN

 schmidt

Dosage and conveyor systems

Conveyor belt system

The Stratos systems combine efficiency with safety; the conveyor belt system provides a reliable system for practical everyday applications. The integrated conveyor belt is fibre-reinforced, and its endless V-profile ensures even transportation of the spreading material, while a stainless steel guide plate makes it possible for the belt to glide at full surface contact and minimum friction.

To protect the conveyor belt, the load of the spreading material is reduced by a load distributor. The precise dosage of all commercially available spreading materials is enabled by the accurately adjustable belt speed as well as a feed gate. The feed gate is equipped with an integrated lump crushing function to ensure

flawless operation: Lumps in the spreading material are broken up at constant pressure, preventing stones and foreign particles from blocking or damaging the system. The constant feed rate allows for high dosing accuracy, irrespective of the spreading material's moisture content.

The fitted chains ensure the controlled delivery of the spreading material to the chute. The optimised belt cleaning system prevents salt from running onto the truck's loading platform, which facilitates the vehicles' maintenance. The lateral sealing between the hopper and the conveyor belt by vertical belt wipers additionally enhances the simplified maintenance effect.

Benefit from:

- Faster and easier servicing / maintenance: Optimised conveyor belt system and improved belt cleaning system
- No operating errors during application: Clear feed gate operation of the conveyor belt system
- Driver-independent quality and reliability during spreading material application: New dosing disc in the auger system





Auger system

The basic component of the Stratos auger system is a Flex auger with two-stage pitch. It is a cold-formed spiral with an open structure that allows for effort-saving transport at low breakaway torque. A variable thread ensures even discharge of the hopper, having a direct positive effect on the centre of gravity of truck's spreader.

Our new dosing disc (see fig. below, coloured in red) achieves even dosage, which is guaranteed by a closed-loop control circuit: Continuous target-actual comparisons ensure accurate and constant speed of the system. A cover fitted as a standard relieves the auger of the spreading material's load, noticeably increasing its service life. The auger system is driven by a hydraulic motor with gears; its high torque ensures safe and reliable start-up.

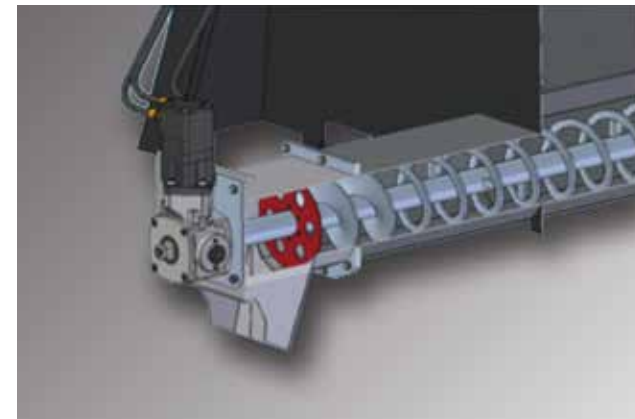



Benefit from:

- Long service life and low maintenance costs:
Use of corrosion-resistant PE
- Maximum flexibility:
Increased tank capacity permits an individually adjustable pre-wet salt admixture of FS 25 to FS 35
- Maximum user friendliness:
Ergonomically optimised filling and drain connection
- Increased functional reliability:
Level switch with automatic switch-off mechanism
Optimised overflow protection
Point of intake is positioned at the centre of the tank
- High tank filling speed:
Large hose cross-sections
Less downtime during filling/loading

Pre-wet equipment

Pre-wet equipment

The Stratos pre-wet equipment is accurately adapted to the hopper size, the capacity of which has been increased, permitting an individually adjustable pre-wet salt admixture of FS 25 to FS 35.

The laterally arranged liquid tanks with integrated baffles are made of impact-proof and cold-resistant PE. The point of intake is located at the centre of the tank, which permits trouble-free operation even in challenging mountain regions. The integrated level indicator enables your driver to always keep track of the spreading material consumption;

the stainless steel filling and drain connection ensures reliable filling, which is considerably accelerated due to the integrated valve-filter combination, large duct cross-sections and maximum user friendliness.

When switching on the pre-wet setting, automatic speed regulation is ensured by a hydraulically operated high-performance brine pump made of anti-corrosive PE with dry-running prevention, with maximum accuracy being guaranteed by an integrated speed-reporting sensor.

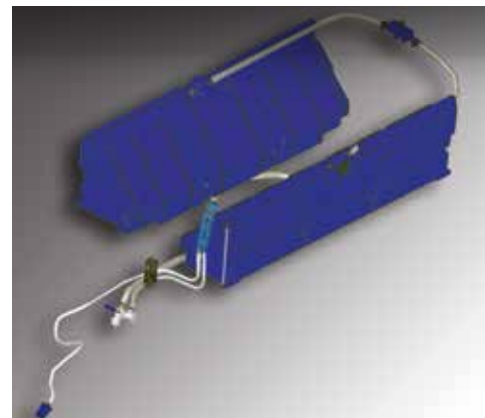

The difference between spreading dry and pre-wetted salt

Salt represents the most important de-icing material. There are several procedures for its application, enabling differentiated de-icing operations: In dry salt spreading, untreated salt is applied to the ground, whereas in pre-wetted salt spreading it is mixed with brine from appropriate tanks prior to its application. This makes the salt stick more quickly to the treated surface in addition to accelerating and extending its effect. Since this technique involves hardly any bounce and scatter, it is very cost-effective and environmentally friendly.

Another variant is referred to as brine spraying, in which brine (a solution of salt in water) is applied to the ground. This procedure is designed for preventive de-icing at temperatures as low as -6 degrees, permitting a 20 percent reduction in salt use.

Distribution systems

Premium distribution system

In order to apply the spreading material as efficiently as possible, we have advanced our distribution systems to achieve best possible material flow by integrating a PE chute and optimising the outlet angle of our mixing system. This is enabled due to the path of the spreading material, which is transported via the Premium mixing system to the centre of the spreading disc and is optimally distributed until it is discharged. As a result, a homogenous mixture is produced, which is ejected dynamically as a concentrated jet against the direction of travel.

The swivelling mechanism of the spreading disc allows for adjusting a symmetrical or asymmetrical spreading pattern either manually or electronically via the control panel. This technique makes it possible to maintain the size of the spreading surface and achieve an accurately defined spreading pattern with spreading widths ranging from 2 – 10 m, 3 – 12 m or 4 – 14 m. To maximise the service life and safety, the corresponding spreading control is accommodated at a well-protected position.



„Premium“ distribution system: For a thoroughly mixed solution of brine and salt

1. Salt and brine feed
2. First mixing due to different supply angles
3. Axial mixing at the cone
4. Radial mixing in the open space between cone and flights
5. Homogeneous mixture leaves the spreading disc in such a way that airstream influences are compensated for.

A PE chute with stainless steel outlet ensures smooth material flow.

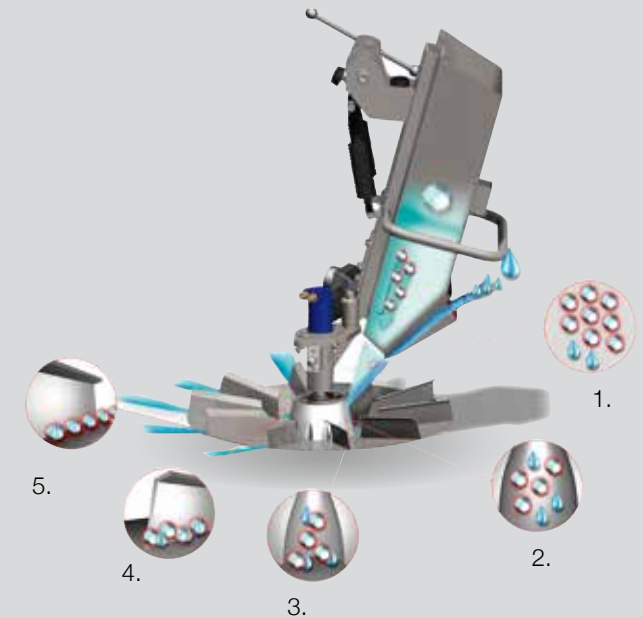

Premiumplus distribution system

The Stratos Premiumplus mixing system is a further development of our Premium mixing system. In the plus variant, the mixture of salt and brine is completely prepared in a mixing chamber by means of centrifugal force and rotary movement. The rotary mixing chamber is operated electronically via the control panel and can be set to create either a symmetrical or an asymmetrical spreading pattern. The optimised scoop geometry and dimensions ensure a high level of precision over the selected spreading widths of 2 – 10 m, 3 – 12 m or 4 – 14 m. Of course, the spreading control of the Premiumplus system is also accommodated at a protected position.

New – Kick-back protection on the spreading disc

On contact, the entire distribution system folds away to the back, preventing damage to your spreader.



Benefit from:

- Improved flow properties of the spreading material:
Use of PE, Optimised angle of outlet
- Protection against damage: On contact, the entire distribution system simply folds away to the back
- Even more stability of the distribution system:
The attachment points have been further optimised
- Easier folding-up of the distribution system:
The gas-pressure spring has been further optimised
- Increased functional reliability: Accommodation of spreading control at a protected position
- Lower amounts of spreading material applied:
- Increased accuracy of distribution thanks to optimised mixing chamber system
- Road-speed related spreading pattern adjustment

Drive options

The Stratos drive systems are designed for maximum efficiency at minimum costs. Please find an overview below:

Vehicle hydraulic system – The municipal solution

In this variant, the spreader is simply powered by the existing hydraulic system of the carrier vehicle. The regulation of power requirement in LS hydraulic systems offers several advantages: Due to the low power requirement during spreading operations, the carrier vehicle needs to share less performance, the positive consequence being lower fuel and oil consumption.

Wheel drive – The conventional solution

The drive power comes from a separate wheel running at the truck's rear. The wheel's position has been optimised to enable easy and trouble-free connection to the driveshaft for discharge.

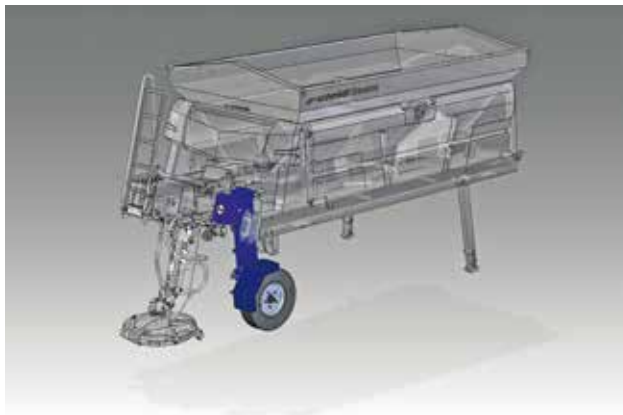

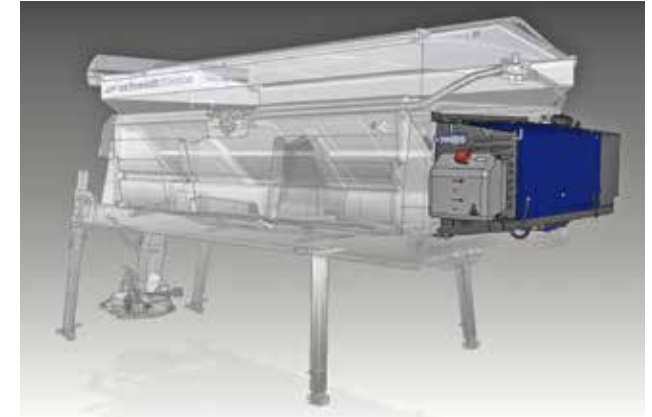
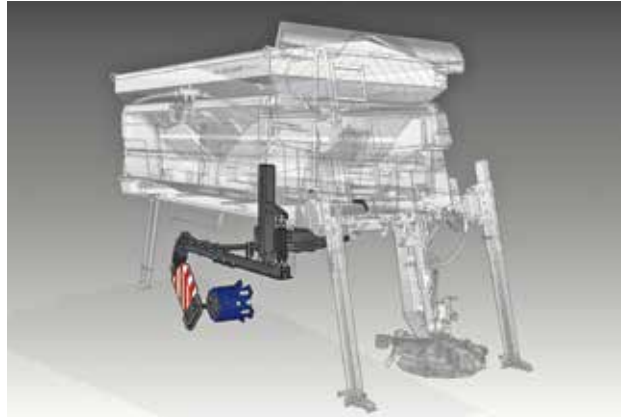

**Innovative, CO2-neutral Rotopower –
The patented solution**

With the Rotopower drive, you experience patented innovation in daily practice. In this system, the required drive power is taken directly off the rear wheel hub and used further to power the vehicle, thus creating a fuel-saving solution with optimum performance.

Engine drive – The vehicle-independent solution

The diesel engine is integrated in the spreader's front, which reduces the additionally required body length. The start/stop function can now be actuated both via the control panel in the driver's cab and directly on the engine. The performance of the engine drive has also been designed to have minimum power requirements, resulting in correspondingly low fuel consumption.

Benefit from:

- Long service life and low maintenance costs: Maximum protection thanks to optimised design
- Maximum flexibility: With the vehicle-independent engine, Rotopower or wheel drive
- Stop-and-go in no time: Convenient starting and stopping of the diesel engine from the driver's cab
- Improved accessibility and safety during stationary discharge: Use of a separate compartment
- Reduced error rate and increased serviceability: Optimised position of the Minimess connections in the compartment

Control and information systems

The new Schmidt EvolutionLine comprises three professional operating concepts and provides professional solutions to make your work easier and more efficient. The modular structure of the concepts offers the huge advantage of a completely flexible configuration, making it possible to precisely adapt the control panels to your needs.

EC control panel – The entry-level solution

The compact EC control panel meets all basic requirements and permits easy and smooth operation of your spreader. Thanks to the efficient button assignment the handling is very straightforward and is complemented by ergonomic click-turn control knobs fitted as a standard.

EP control panel – The extensible solution

With the EP control panel, you receive an extensible solution that can be flexibly adapted to your requirements. The control panel has an ergonomic design and is accommodated in a sturdy housing. The standard equipment comprises a frost-

proof, backlit display, ergonomic click-turn control knobs, which have been developed specifically for spreading operations, as well as illuminated push buttons that can be assigned individually in dependence on the specific application.

Overview of add-on modules:

SmartCare: GPRS modem for online data transfer

GPS for position determination

Wireless module

ES control panel – The premium solution

With the ES control panel of the Schmidt Evolution Line, you receive the smartphone among the control panels that meets all current and future operational requirements. The frost-proof 7" colour touchscreen display is accommodated in a splash-proof, sturdy housing and ensures comfortable handling, in addition to a long service life. The spreading density, spreading pattern and spreading width are adjusted via ergonomic click-turn control knobs and eight additional

illuminated push buttons are in place for the actuation of primary and menu-dependent functions. Equipped with optional additional components, the ES control panel can be easily upgraded to become the high-tech control centre of your spreader.

Overview of add-on modules:

- SmartCare: GPRS modem for online data transfer
- GPS for position determination
- Wireless module
- AutoLogic: GPS-guided spreading operations
- ThermoLogic: Temperature-dependent dosage





ThermoLogic
Temperature-dependent dosage



GPS
Position determination



SmartCare
GPRS online data transfer



AutoLogic
Automatic spreading operations

Benefit from:

- **From basic to high-tech equipment:**
 - All models are equipped with all basic functions
 - Flexible upgrade with add-on modules
- **Improved planning of winter service operations**
 - Control and optimisation through easy performance data collection (SmartCare)
 - Variable resource planning by using AutoLogic
 - Reduced operating costs by using ThermoLogic
- **Haptic feedback**
 - Specially developed click-turn control knobs and push buttons
 - Primary functions can be easily actuated even when wearing gloves
- **Maximum operational comfort and user friendliness**
 - Glare-free display with automatic adjustment of luminosity via an integrated sensor
 - Capacitive 7" colour touchscreen in the ES variant
 - Application-specific and individual assignment of illuminated push buttons
 - Straightforward menu structure to quickly adapt the control system to the operating conditions
- **Easier spreader mounting and demounting**
 - Wireless control – Cable connections are no longer needed

SmartCare 
SOLUTIONS



Stratos spreaders

Conveyer belt and auger dosage system

	Stratos trailer spreaders		Stratos mountable spreaders – Big range							
Hopper capacity Solid material (m³)	4.0	5.0	4.0	5.0	6.0	7.0	8.0	9.0	10.0	12.0
Tank capacity Liquid material (l)	1,850	1,850	1,850 / 2,400	1,850 / 2,400	2,400	3,000	3,000	3,000	3,000 / 5,500	3,000 / 5,500
Dosage systems (B belt / S auger)	B		B/S					B		
Distribution systems	Premium spreading disc (5-zone mixing system) / Premiumplus spreading disc (mixing chamber system)		Premium spreading disc (5-zone mixing system) / Premium ^{plus} spreading disc (mixing chamber system)							
Spreading width from-to (m)	2–10 or 3–12		2–10 or 3–12 or 4–14							
Demount systems	-		RoRo system / Demount legs / Hooklifts / Fixed-mounted systems / Skip handlers					RoRo system / Demount legs / Hooklifts / Fixed-mounted systems		
Drive systems	Integrated drive / Vehicle hydraulic system		Vehicle hydraulic system / Rotopower / Wheel drive / Engine drive					Vehicle hydraulic system		
Control systems	EC / EP / ES		EC / EP / ES							
Hopper length (mm)	3,000		3,000 or 3,600		3,600	4,200			4,510	
Mounting length (mm)	aprox. 3,500		aprox. 3,500 / 4,100 / 4,700		aprox. 4,100 / 4,700		4,700			5,700
Hopper width (mm)	2,000		2,000					2,150		
Frame width (mm)	2,000		1,950 (RoRo) 2,000 (demount systems)					2,182–2,582		
Hopper height (mm)	1,540	1,710	1,490 to 1,600	1,630 to 1,770	1,650 to 1,770	1,770	1,885	2,005	2,045	2,235
Empty weight (basic version) (kg)	aprox. 2,415	aprox. 2,440	aprox. 1,015–1,140	aprox. 1,040–1,170	aprox. 1,125–1,340	aprox. 1,375	aprox. 1,420	aprox. 1,455	aprox. 1,880–2,610	aprox. 1,945–2,675



Scan to discover Aebi Schmidt on YouTube.

Aebi Schmidt Holding AG
Marketing and Communication

Technical data is subject to change.
Illustrations are not binding.

Status 03/2019 Copyright © Aebi Schmidt Holding AG.
All rights reserved. Errors and amendments excepted.

 **aebi schmidt**
group

www.aebi-schmidt.com