



EG5100 **robustOS** Pro

Industrial Edge Computing Gateway
 2 x Ethernet + 2 x RS232/RS485 + 2 x DI/DO
 Optional Wi-Fi, Bluetooth & GPS/GNSS



INTRODUCTION

Robustel's EG5100 series is a new generation of industrial edge computing gateways, supporting global 4G/3G/2G networks for cellular backhaul, with a fully-fledged Debian Operating System able to support thousands of existing or new ARMv7 (RPI compatible) based applications.

For many years, customers have used Robustel Gateways as a combination of cellular router + embedded PC and the EG5100 series takes the compute power to the next level.

EG5100 supports Docker for easy deployment of applications and benefits from '**RobustOS Pro**' – Robustel's latest router OS with enhanced cybersecurity, advanced GUI and a myriad of software features including VPNs, Smart Roaming, SMS remote control and more.

RCMS is Robustel's free router monitoring service that is fully compatible with the EG5100. It allows customers to see a location overview of their routers quickly and simply on a map.

Features such as data usage, signal strength, current network and much more can then be viewed on a per router basis. Over-the-air updates are supported for Firmware, router configuration and Apps serving as essential "insurance" if anything was not quite right during deployment.

You can try Robustel's free router management platform by signing up here: <https://rcms-cloud.robustel.net>



KEY FEATURES

- Highly stable 4G/3G/2G cellular connectivity with global band coverage
- High performance compute engine with 8 GB eMMC Flash for running complex customer applications
- 'Docker' containerisation supported
- 802.11ac Wi-Fi (optional) supporting AP and Client modes
- Bluetooth (optional), Bluetooth 5.3 compliant
- 2 x RS232/RS485 (software configurable) ports for connection to industrial/legacy devices
- 2 x DI & 2 x DO for simple monitoring and control
- Dual SIM card slots for redundant communications
- Wide Operating Temperature range for industrial applications
- Full Modbus TCP and Modbus RTU support including MQTT transfer to mainstream cloud platforms
- Supports C, C++, Java, Python, Node.js etc. for users to develop their own applications
- More than 50,000 applications from Debian repository currently available
- Wireguard/IPsec/OpenVPN/GRE/L2TP/PPTP/DMVPN + more VPN options
- Supports RCMS – Robustel's router/gateway management platform for effective management of large estates of devices

APPLICATION EXAMPLE

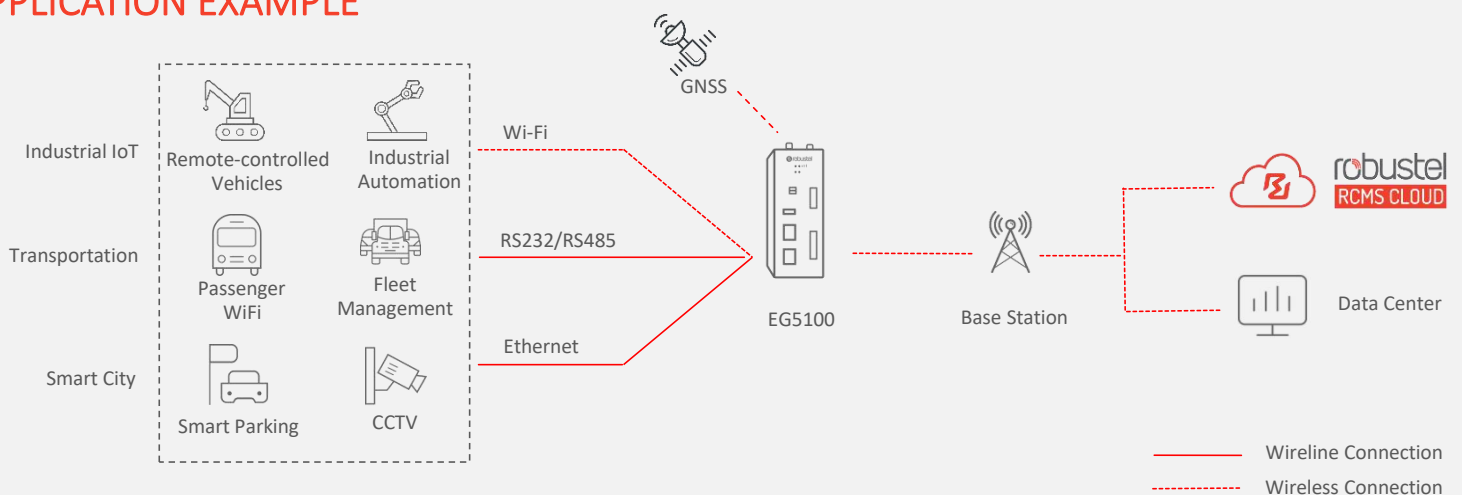

SPECIFICATIONS

Hardware System

CPU	ARM Cortex-A7, 792 MHz
RAM	512 MB DDR3
Flash	8 GB eMMC

Cellular Interface

Number of antennas	2
Connector	SMA-K
SIM	2 x Mini SIM (2FF)

GNSS Interface (Optional)

Number of antennas	1
Connector	SMA-K
Technology	GPS/GLONASS/BeiDou (Compass)/Galileo/QZSS

Serial Interface

Type	2 x RS232/RS485 (software configurable)
Connector	6-pin 3.5 mm terminal block with lock
ESD protection	±8 KV
Baud rate	300 bps to 115200 bps
Signal	RS232: TXD, RXD, GND RS485: Data+ (A), Data- (B), GND

DI/DO Interface

Number of ports	2 x DI + 2 x DO, wet contact
Connector	8-pin 3.5 mm terminal block with lock (DI/DO)
Isolation	Bi-directional optocoupler (DI), Single directional optocoupler (DO)
Absolute maximum VDC	+ 30V DC
Absolute maximum ADC	100 mA
Signal definition	DI1+, DI1-, DI2+, DI2-, DO1+, DO1-, DO2+, DO2-

Wi-Fi Interface (Optional)

Number of antennas	2
Connector	RP-SMA-K
Standards	802.11a/b/g/n/ac, 2 x 2 MIMO, supports AP and Client modes
Frequency bands	2.412 - 2.484 GHz (2.4 GHz ISM band) 4.915 - 5.925 GHz (5 GHz ISM band)
Security	WEP 64-bit and 128-bit encryption with H/W TKIP processing WPA/WPA2 (Wi-Fi Protected Access) AES-CCMP hardware implementation as part of 802.11i security standard
Data rate	802.11n: up to 300 Mbps - 2 x 2 MIMO 802.11ac: up to 866.7 Mbps (80 MHz channel)

Bluetooth Interface (Optional)

Number of antennas	1 (Multiplexing Wi-Fi antenna)
Connector	RP-SMA-K
Standards	Bluetooth 2.1 and 3.0 + Enhanced Data Rate (EDR) + Bluetooth 5.3

Ethernet Interface

Number of ports	2 x 10/100 Mbps, LAN or WAN
Magnet isolation protection	1 KV

Others

Reset button	1 x RST
USB	1 x USB 2.0 (host), Type A, 5V, 500mA
LED indicators	1 x RUN, 1 x MDM, 1 x USR, 1 x Signal
Watchdog	External

Software (Basic features of RobustOS Pro)

Network protocols	PPP, PPPoE, TCP, UDP, DHCP, ICMP, NAT, HTTP, DNS, NTP, SMTP, Telnet, VLAN, HTTPs, DNS, ARP, NTP, SMTP, Telnet, VLAN, SSH2, DDNS, etc.
VPN tunnel	IPsec, OpenVPN, GRE
Firewall	DMZ, anti-DoS, Filtering (IP/Domain name/MAC address), Port Mapping, Access Control
Remote management	Web, CLI, SMS
Serial port	Transparent, TCP Client/Server, UDP, Modbus RTU Gateway
Others	Smart Reboot, Data Guard, Smart Roaming

SDK

Operating System	RobustOS Pro (Based on Debian 11(bullseye))
Supported programming language	C, C++, Python, Java, Node.js etc. (for users to develop own applications)
Debian repository available	
Flash available for SDK	6 GB
RAM available for SDK	256 MB

App Center (Available Apps for RobustOS Pro)

Apps*	L2TP, PPTP, DMVPN, VRRP, QoS, SNMP, Language, RCMS, Dynamic route, Captive Portal, Modbus Master, etc.
-------	--

*Request on demand. For more Apps please visit www.robustel.com.

Power Supply and Consumption

Connector	2-pin 3.5 mm terminal block with lock
Input voltage	9 ~ 60V DC
Power consumption	Idle: 3W Data link: 10W (peak)

Physical Characteristics

Ingress protection	IP30
Housing & Weight	Metal, 568 g
Dimensions	49 x 105 x 128 mm
Installations	Desktop, wall mounting and 35 mm DIN rail mounting
Operating temperature	-40 ~ +70 °C
Storage temperature	-40 ~ +85 °C
Relative humidity	5 ~ 95% RH

Regulatory and Type Approvals (*In progress)

Environmental	RoHS2.0*
---------------	----------

ORDERING INFORMATION

Model	PN	Wi-Fi + BLE	Cellular	Frequency Bands*	Country/Region	Certification (*In progress)
EG5100-A2ACA-4L-A06GL	B066706	-	✓	4G: LTE FDD: B1/B2/B3/B4/B5/B7/B8/B12/B13/B18/B19/B20/B25/B26/B28 LTE TDD: B34/B38/B39/B40/B41 3G: WCDMA: B1/B2/B4/B5/B6/B8/B19 2G: GSM: B2/B3/B5/B8	Global	CE*, RCM*
EG5100-A2CCA-4L-A06GL	B066708	✓	✓	4G: LTE FDD: B1/B3/B5/B8 LTE TDD: B34/B38/B39/B40/B41 3G: WCDMA: B1/B5/B8 2G: GSM: B3/B8	China	CCC*
EG5100-A2ECA-4L-A23CN	B066711	✓	✓	4G: LTE FDD: B1/B3/B5/B8 LTE TDD: B34/B38/B39/B40/B41 3G: WCDMA: B1/B5/B8 2G: GSM: B3/B8	Global	CE*, RCM*
EG5100-A2ECA-NU	B066712	✓	-	-	Global	CE*, RCM*

*For more information about frequency bands in different countries, please contact your Robustel sales representative.