

Freyssinet Mechanical Bearings



D E S I G N , B U I L D , M A I N T A I N



FREYSSINET
SUSTAINABLE TECHNOLOGY

The Freyssinet Group

Freyssinet brings together **an unrivalled set of skills in the specialist civil engineering sector**. The company implements solutions with high added value in two major fields: construction and repairs.

Freyssinet is involved in numerous projects across five continents, making it the world leader in its specialist areas of:

- Prestressing;
- Construction methods;
- Cable-stayed structures;
- Structural accessories;
- Repairs;
- Structural reinforcement and maintenance.

Freyssinet is highly involved in sustainable development issues and has set up a number of initiatives to reduce the environmental impact of its projects and enhance its social responsibility policy.

Freyssinet is a subsidiary of the Soletanche Freyssinet Group, a world leader in the soils, structures and nuclear sectors.

*Cover photo:
Tours-Bordeaux high-speed railway line - Claix Viaduct*



Bearings are a major component of structures, and their function means that they play a decisive role in the operation of those structures. As such, bearings must be designed, manufactured and installed by specialists.

As a major player in the field of construction, Freyssinet has developed a wide range of bearings. Freyssinet designs and provides the right solution to meet its customers' needs for every type of structure.

Freyssinet's bearings are manufactured in house, CE marked and are officially approved in many countries.

Areas of use

Bearings are most commonly used to provide the connection between the piers and deck of a bridge. Freyssinet bearings can also be used in a number of other areas, such as stadiums, pipelines and all types of buildings.

Contents

3
Design

4
The different types of bearing

6
Tetron CD pot bearings

10
Tetron SB spherical bearings

14
Special bearings

16
Options

19
Fastening systems

20
Freyssinet expertise

22
Successful projects

Our primary concern: ensuring everyone's safety



Our "Sustainable technology" signature expresses our commitment to offering our customers sustainable solutions that respect the environment, and to providing our employees with an environment where safety, risk management and innovation are a constant state of mind.

Managing safety on our sites is therefore our primary duty towards our employees worldwide, whatever the local regulations.

We are fully committed to the goal of "Zero Lost Time Injuries"; our rules, our "non-negotiables" and our in-house tools ensure that this commitment will become reality.

DESIGN

Excellent knowledge of how structures operate is vital in identifying the most appropriate types of bearing. The diagrams below show the most common bearing layouts underneath a bridge deck. Because every structure is different, the designer must choose the most appropriate solution depending on the constraints imposed.

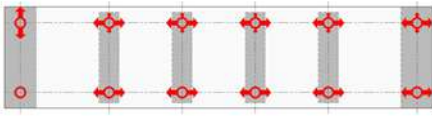

Fixed abutment:

This layout absorbs significant longitudinal loads (braking, for example).

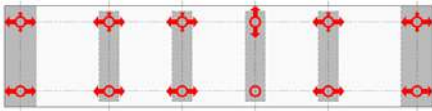

Fixed pier:

This layout distributes the movements of the deck in order to balance the movement of joints on either side.

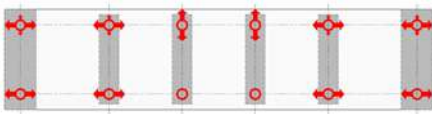

Two fixed piers:

There is significant distribution of longitudinal horizontal loads. The piers contribute to the absorption of dynamic loads (earthquakes, emergency braking by a train, etc.).

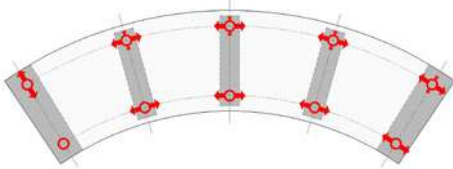

Curved structure, bearings at a tangent to the direction of movement:

The joints work parallel to the axis of the structure.

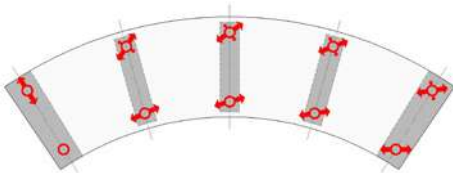

Curved structure, guided sliding bearings facing towards the fixed point:

The joints work at an angle to the structure. Only the lateral operating loads are exerted on guided bearings.

Freyssinet bearings are designed to ensure that loads are transferred between the superstructure and its supports, and to enable movement and rotation. Each range is therefore broken down into three types of bearing:

Free bearings

These transfer the vertical loads and allow all translational and rotational movements of the superstructure.

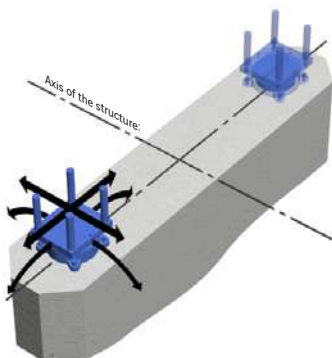

Guided bearings

These transfer the vertical loads and the horizontal loads in one direction. Translation in the perpendicular direction is allowed, as is rotation.

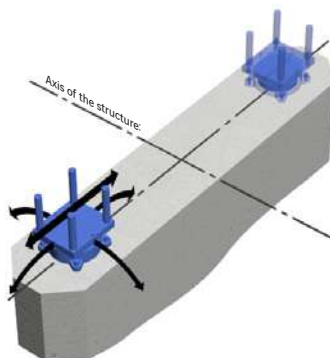

Fixed bearings

These transfer all vertical and horizontal loads, while allowing rotation of the superstructure.

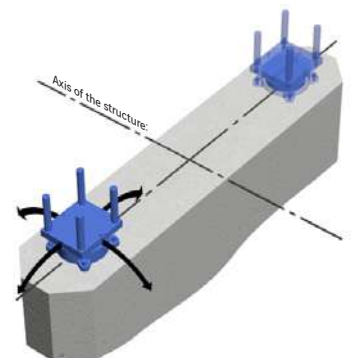

Friction must be taken into account in the directions in which translational movement is allowed, in accordance with the code applied (generally 3%).

THE DIFFERENT TYPES OF BEARING

Bearings are split into four main families, each of which meets different criteria. These are:

- Elastomeric bearings
- Pot bearings
- Spherical bearings
- Special bearings

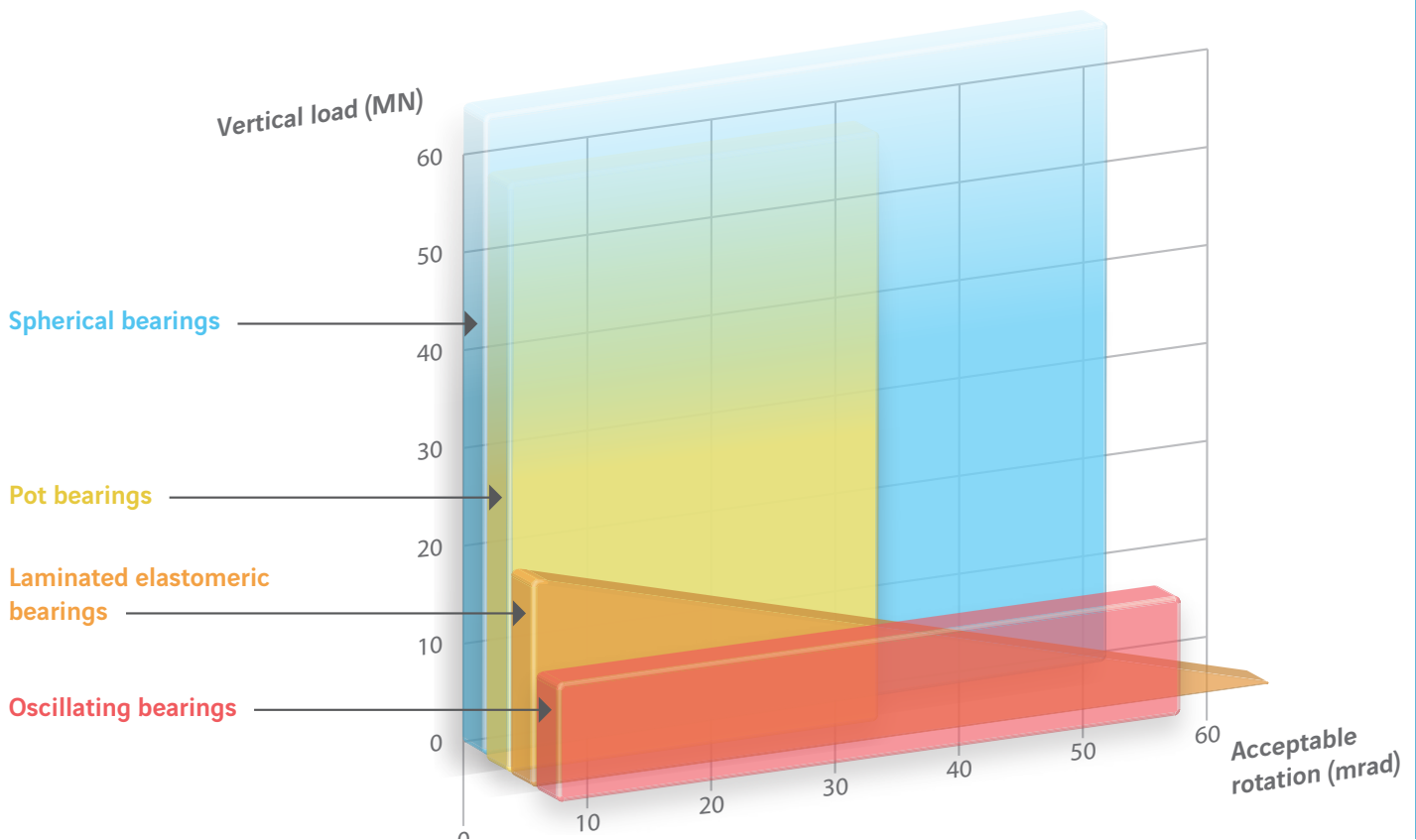

Selection criteria:

One of the selection criteria for bearings is the vertical load applied and the acceptable concomitant rotation.

The other selection criteria mainly derive from the functions that the bearing must perform, such as:

- Blocking rotation in a given direction;
- The intensity of the horizontal loads;
- How aggressive the environment is (type of environment);
- Ease of maintenance;
- Earthquake input (zone);
- Space constraints;
- Durability.

Type of bearing	Vertical load	Horizontal load	Longitudinal movement	Transverse movement	Rotation
Elastomeric	●●●○	●●●○	●●●○	●●●○	●●●●
Pot	●●●●	●●●○	●●●●	●●●●	●●●○
Spherical	●●●●	●●●○	●●●●	●●●●	●●●●
Oscillating linear	●●●○	●●●○	●●●●	●●●●	●●●●
Shear key	-	●●●●	●●●●	-	●●●○
Shear pin	-	●●●●	-	-	●○○○
Pad	●●●○	●●●○	●●●●	●●●●	●●●●

ELASTOMERIC BEARINGS

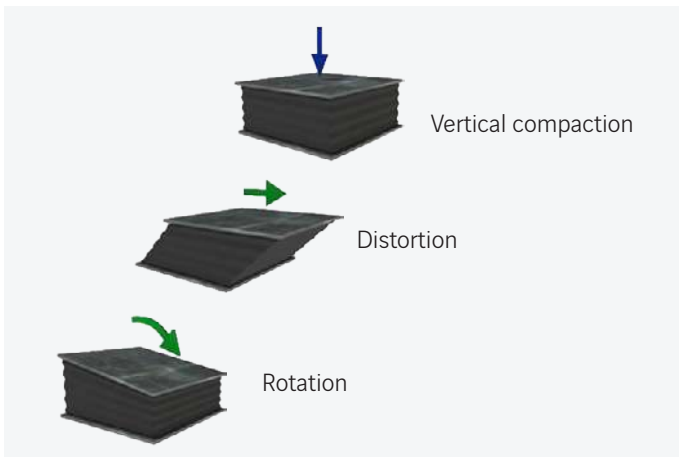

Elastomeric bearings are used for vertical loads generally less than 18,000 kN. The deformation capacity of the bearing determines the acceptable movements. The permissible load decreases as the movements increase. These bearings are made up of a series of elastomeric layers and steel plates.



See **Elastomeric Bearing Brochure** for more information.

POT BEARINGS

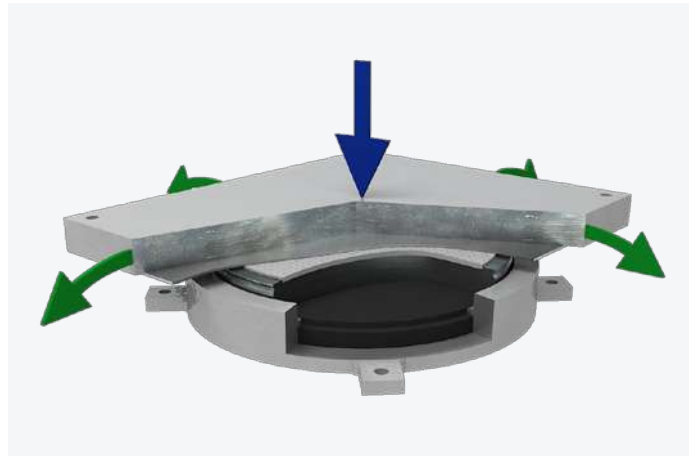

Pot bearings are used to take up very large vertical loads.

They are made up of an elastomeric disc confined between a steel pot and a circular piston, and can withstand much greater loads than a conventional elastomeric bearing. The deformation of the elastomer defines the rotation capacity of the bearing (up to 30 mrad).

SPHERICAL BEARINGS

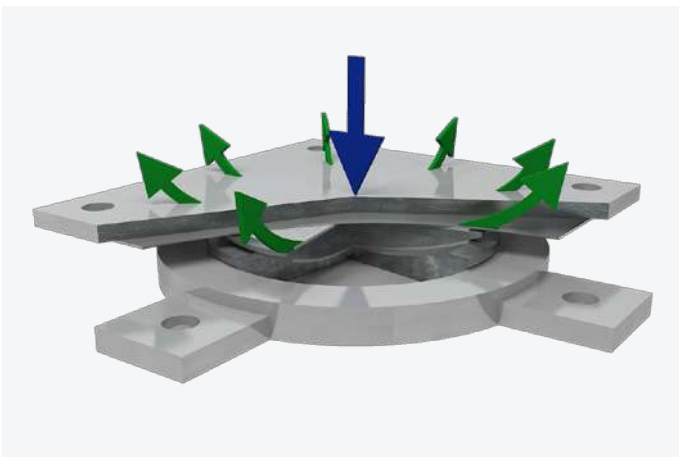

Spherical bearings can withstand both large vertical loads and significant rotation (up to 50 mrad). They do not contain any elastomeric components, and rotation takes place on a spherical face, by contact between a sliding material and a chrome steel surface.



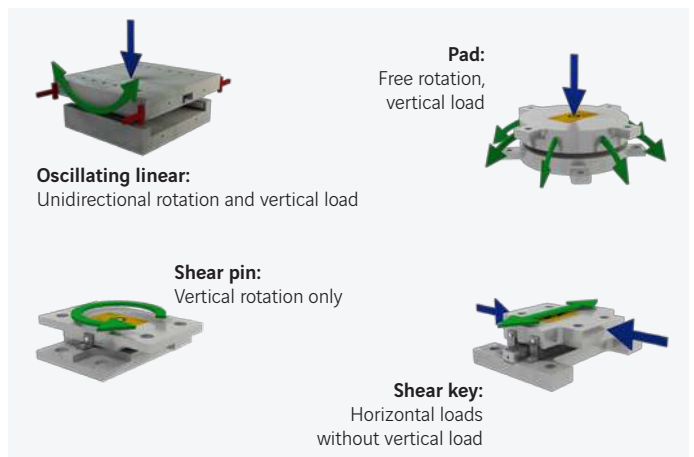

SPECIAL BEARINGS

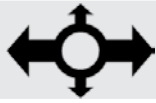

Special bearings do not contain any elastomeric components. All of the functions are provided by steel/steel contact or sliding surfaces. There are several types of special bearing (see above).

TETRON CD POT BEARINGS

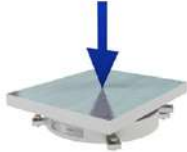
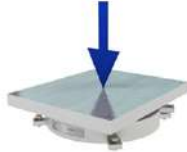
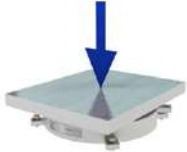
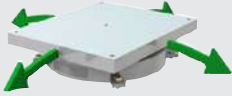
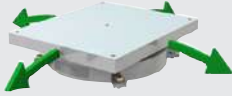
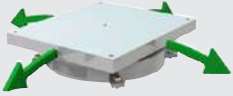
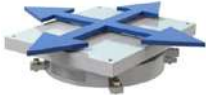
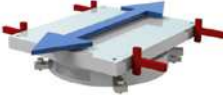
There are three types of bearing, distinguished by the movements required:

Type	Free sliding bearing	Guided sliding bearing	Fixed bearing
	GL	GGL/GGT	FX
Symbol			
Vertical load			
Rotation	 Up to 30 mrad	 Up to 30 mrad	 Up to 30 mrad
Movement Horizontal	 Multidirectional	 Unidirectional	 Blocked

Design basis

The structure of the bearings is designed on the basis of the following parameters:

- Vertical load;
- Acceptable movement;
- Acceptable rotation;
- Exposure temperature;
- Acceptable stress on the supports;
- Horizontal load.

The design can be produced in accordance with various standards, the most common of which are:

- EN 1337 (European Standard);
- BS 5400 (British Standard);
- AASHTO LRFD 2012 (US Standard);
- AS 5100 (Australian Standard).

Designation

The designation of TETRON CD bearings identifies their main characteristics.

GL Free sliding bearing	20,000 Vertical load at ULS in kN	•	250 Total acceptable longitudinal movement in mm	•	40 Total acceptable transverse movement in mm
GGT Transverse guided bearing		-	800 Vertical load at ULS in kN	•	40 Total acceptable transverse movement in mm
GGL Longitudinal guided bearing		-	800 Transverse load at ULS in kN	•	40 Total acceptable longitudinal movement in mm
FX Fixed bearing		-	900 Horizontal load at ULS in kN (resultant of x/y*)		

This gives the following designations, for example:

- TETRON CD GL 20,000.250.40
- TETRON CD GGL 20,000-800.40
- TETRON CD FX 20,000-900

*x: longitudinal axis
y: transverse axis

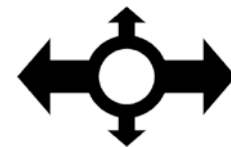

TETRON CD GL POT BEARINGS

This free sliding pot bearing is made up of a pot, an elastomeric disc and a piston covered with a PTFE plate on which the upper plate can slide freely. The pot is fixed to the support (pier, abutment, column, etc.) and the upper plate is fixed to the superstructure.

This model is designed to permit horizontal movements, without any constraint other than the internal stresses.

Bearings with $\pm 50\text{mm}$ longitudinal and $\pm 20\text{mm}$ transverse movement

	EN				BS				AASHTO				AS			
	ΦA	B	C	H	ΦA	B	C	H	ΦA	B	C	H	ΦA	B	C	H
GL 500 . 100 . 40	160	330	260	88	150	315	230	81	180	350	265	86.5	155	295	230	81.5
GL 1,000 . 100 . 40	210	350	305	90	225	335	275	81	240	410	325	86.5	230	335	280	86.5
GL 1,500 . 100 . 40	265	370	335	100	280	365	310	95	280	455	370	93.5	295	370	315	100.5
GL 2,000 . 100 . 40	320	400	365	105	330	395	340	95	325	495	410	93.5	345	405	350	110.5
GL 3,000 . 100 . 40	400	450	415	124	405	445	405	109	405	560	475	104.5	425	460	425	124.5
GL 4,000 . 100 . 40	460	490	465	138	465	490	470	113	480	615	530	112.5	490	510	490	133.5
GL 5,000 . 100 . 40	515	525	520	147	520	530	525	123	540	670	585	124.5	545	550	550	142.5
GL 6,000 . 100 . 40	565	570	570	156	570	575	575	127	600	715	630	137.5	600	600	600	156.5
GL 8,000 . 100 . 40	655	655	655	175	660	660	660	147	700	785	730	161.5	690	695	695	171.5
GL 10,000 . 100 . 40	730	730	730	189.2	735	740	740	155	795	870	820	173	775	775	775	190.5
GL 12,000 . 100 . 40	800	805	805	213.2	805	810	810	164	875	940	895	201	845	845	845	204.5
GL 14,000 . 100 . 40	865	865	865	222.2	870	875	875	188	955	1,000	970	203	920	920	920	223.5
GL 16,000 . 100 . 40	935	930	930	228.2	930	935	935	193	1,025	1,060	1,040	216	980	980	980	234
GL 18,000 . 100 . 40	980	985	985	235.5	990	990	990	207	1,090	1,110	1,100	223	1,060	1,040	1,040	242
GL 20,000 . 100 . 40	1,050	1,040	1,040	255.5	1,040	1,045	1,045	208	1,155	1,165	1,165	235	1,120	1,100	1,100	251
GL 24,000 . 100 . 40	1,160	1,140	1,140	267.5	1,140	1,145	1,145	227	1,270	1,275	1,275	261	1,235	1,205	1,205	267
GL 28,000 . 100 . 40	1,255	1,230	1,230	285.5	1,230	1,235	1,235	243	1,375	1,375	1,375	274	1,330	1,300	1,300	290
GL 30,000 . 100 . 40	1,285	1,270	1,270	291.5	1,275	1,280	1,280	243	1,425	1,425	1,425	279	1,380	1,345	1,345	293
GL 35,000 . 100 . 40	1,400	1,375	1,375	295.5	1,375	1,380	1,380	260	1,535	1,535	1,535	301	1,480	1,450	1,450	314
GL 45,000 . 100 . 40	1,595	1,555	1,555	337.7	1,560	1,565	1,565	291	1,745	1,745	1,745	341	1,695	1,645	1,645	347

Dimensions in mm

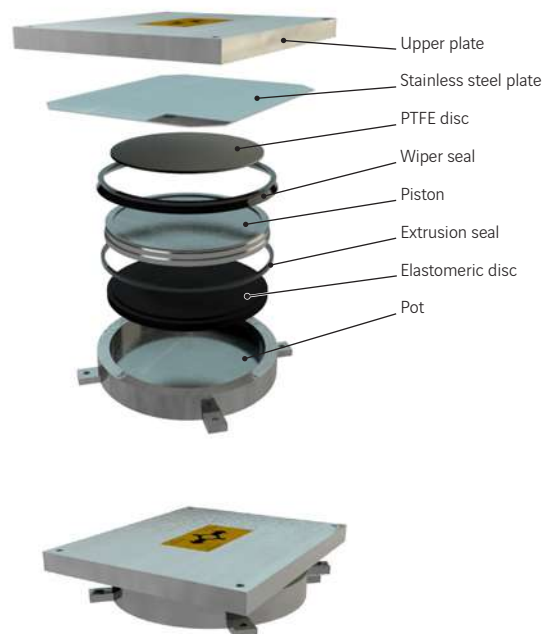

Bearings with $\pm 200\text{mm}$ longitudinal and $\pm 20\text{mm}$ transverse movement

	EN				BS				AASHTO				AS			
	ΦA	B	C	H	ΦA	B	C	H	ΦA	B	C	H	ΦA	B	C	H
GL 500 . 400 . 40	160	630	260	90	150	615	230	80	180	650	265	86.5	155	595	230	81.5
GL 1,000 . 400 . 40	210	650	305	94	225	635	275	80	240	710	325	90.5	230	635	280	90.5
GL 1,500 . 400 . 40	265	670	335	104	280	665	310	94	280	755	370	97.5	295	670	315	99.5
GL 2,000 . 400 . 40	320	700	365	104	330	695	340	99	325	795	410	97.5	345	705	350	109.5
GL 3,000 . 400 . 40	400	750	415	128	405	745	405	108	405	860	475	113.5	425	760	425	123.5
GL 4,000 . 400 . 40	460	790	465	137	465	790	470	112	480	915	530	117.5	490	810	490	132.5
GL 5,000 . 400 . 40	515	825	520	146	520	830	525	122	540	970	585	134.5	545	850	550	142.5
GL 6,000 . 400 . 40	565	855	570	155	570	860	575	126	600	1,015	630	137.5	600	885	600	156.5
GL 8,000 . 400 . 40	655	930	655	175	660	920	660	147	700	1,085	730	161.5	690	950	695	167.5
GL 10,000 . 400 . 40	730	990	730	189.2	735	975	740	155	795	1,170	820	173	775	1,005	775	191.5
GL 12,000 . 400 . 40	800	1,005	805	213.2	805	1,020	810	164	875	1,240	895	200	845	1,055	845	205.5
GL 14,000 . 400 . 40	865	1,075	865	222.2	870	1,065	875	188	955	1,300	970	202	920	1,105	920	224.5
GL 16,000 . 400 . 40	935	1,140	930	228.2	930	1,105	935	193	1,025	1,360	1,040	215	980	1,150	980	234
GL 18,000 . 400 . 40	980	1,170	985	235.5	990	1,145	990	207	1,090	1,410	1,100	222	1,060	1,190	1,040	242
GL 20,000 . 400 . 40	1,050	1,170	1,040	255.5	1,040	1,180	1,045	208	1,155	1,465	1,165	234	1,120	1,230	1,100	250
GL 24,000 . 400 . 40	1,160	1,275	1,140	266.5	1,140	1,250	1,145	226	1,270	1,555	1,275	261	1,235	1,300	1,205	267
GL 28,000 . 400 . 40	1,255	1,355	1,230	280.5	1,230	1,310	1,235	243	1,375	1,645	1,375	274	1,330	1,370	1,300	290
GL 30,000 . 400 . 40	1,285	1,400	1,270	291.5	1,275	1,340	1,280	243	1,425	1,685	1,425	279	1,380	1,400	1,345	293
GL 35,000 . 400 . 40	1,400	1,520	1,375	295.5	1,375	1,410	1,380	260	1,535	1,780	1,535	301	1,480	1,475	1,450	314
GL 45,000 . 400 . 40	1,595	1,640	1,555	337.7	1,560	1,565	1,565	291	1,745	1,960	1,745	340	1,695	1,645	1,645	347

Dimensions in mm

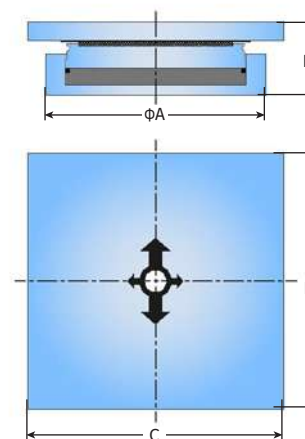

All of these bearings are designed with the following parameters:
 Rotation = 10 mrad
 Strength of concrete underneath bearing = min. 30 MPa
 Strength of concrete above bearing = min. 30 MPa

Bearings with larger loads or strokes, or with different bearing conditions, can be designed on request.



TETRON CD GG POT BEARINGS

This type of guided sliding pot bearing is designed like a free sliding bearing, but with a guide. The guide is secured to the piston, and slots into a groove in the upper sliding plate. In some cases, guidance can be provided by lateral guides.

This bearing model accepts horizontal movement along the axis of the guide and horizontal loads in the perpendicular direction.

Bearings with horizontal load = 10% of vertical load and ±50mm movement



		EN				BS				AASHTO				AS			
		ΦA	B	C	H	ΦA	B	C	H	ΦA	B	C	H	ΦA	B	C	H
GG	500 - 50 . 100	160	350	215	91	155	335	225	81	180	375	245	87.5	155	325	225	81.5
GG	1,000 - 100 . 100	215	380	260	95	225	370	270	81	240	435	305	88.5	235	375	275	86.5
GG	1,500 - 150 . 100	275	410	295	95	285	405	305	90	280	475	345	93.5	300	415	315	95.5
GG	2,000 - 200 . 100	330	440	335	105	330	435	340	90	330	515	385	97.5	350	445	355	100.5
GG	3,000 - 300 . 100	410	515	410	124	410	495	415	104	415	575	445	109.5	435	525	435	119.5
GG	4,000 - 400 . 100	470	570	475	132	470	550	475	114	485	630	515	112.5	500	580	500	128.5
GG	5,000 - 500 . 100	525	615	530	145	525	615	530	122	555	695	580	124.5	555	635	560	141.5
GG	6,000 - 600 . 100	575	655	580	163	580	675	580	126	615	735	640	131.5	610	685	615	150.5
GG	8,000 - 800 . 100	665	720	670	195	670	760	670	137	720	810	745	158	735	795	710	161.5
GG	10,000 - 1,000 . 100	740	755	745	210.2	745	825	750	160	815	885	840	165	820	865	795	180.5
GG	12,000 - 1,200 . 100	815	840	820	228.2	835	905	820	163	895	945	920	184	895	930	870	199.5
GG	14,000 - 1,400 . 100	880	910	885	242.2	895	960	885	177	975	1,020	990	191	960	980	935	218
GG	16,000 - 1,600 . 100	940	965	945	260.2	955	1,015	945	186	1,045	1,070	1,060	207	1,045	1,065	1,005	228
GG	18,000 - 1,800 . 100	995	1,000	1,000	273.5	1,020	1,075	1,005	197	1,105	1,125	1,125	214	1,115	1,120	1,065	242
GG	20,000 - 2,000 . 100	1,050	1,065	1,060	280.5	1,085	1,130	1,060	204	1,170	1,185	1,185	225	1,185	1,180	1,125	246
GG	24,000 - 2,400 . 100	1,150	1,155	1,155	300.5	1,175	1,210	1,160	225	1,290	1,300	1,300	243	1,305	1,285	1,230	267
GG	28,000 - 2,800 . 100	1,245	1,250	1,250	320.5	1,260	1,285	1,250	243	1,400	1,400	1,400	261	1,405	1,370	1,330	290
GG	30,000 - 3,000 . 100	1,285	1,290	1,290	313.5	1,320	1,345	1,295	246	1,450	1,450	1,450	270	1,455	1,415	1,375	303
GG	35,000 - 3,500 . 100	1,580	1,570	1,420	320.5	1,430	1,435	1,400	270	1,570	1,565	1,565	287	1,565	1,505	1,485	319
GG	45,000 - 4,500 . 100	1,670	1,620	1,590	353.7	1,635	1,620	1,585	286	1,775	1,775	1,775	323	1,760	1,680	1,680	360

Dimensions in mm

Bearings with horizontal load = 30% of vertical load and ±200mm movement

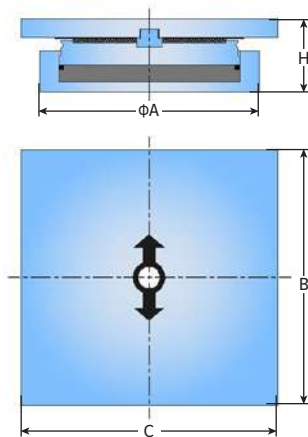

		EN				BS				AASHTO				AS			
		ΦA	B	C	H	ΦA	B	C	H	ΦA	B	C	H	ΦA	B	C	H
GG	500 - 150 . 400	160	655	225	89	165	635	225	85	180	690	260	91.5	170	640	240	85.5
GG	1,000 - 300 . 400	230	710	275	101	240	690	270	86	250	745	315	99.5	255	695	295	90.5
GG	1,500 - 450 . 400	300	730	320	105	295	745	315	93	300	790	360	99.5	325	740	340	103.5
GG	2,000 - 600 . 400	355	765	370	118	340	750	360	102	345	850	395	106.5	380	785	380	107.5
GG	3,000 - 900 . 400	445	840	445	130	430	805	435	109	420	920	475	127.5	460	855	465	125.5
GG	4,000 - 1,200 . 400	530	910	515	137	485	860	500	128	480	950	550	140.5	555	900	540	143.5
GG	5,000 - 1,500 . 400	600	970	575	150	555	910	555	136	540	1,005	620	153.5	620	950	600	165.5
GG	6,000 - 1,800 . 400	660	1,010	625	152	595	950	610	158	595	1,060	680	156.5	685	1,000	655	173.5
GG	8,000 - 2,400 . 400	775	1,095	720	177.2	685	1,010	705	191	700	1,160	795	180	775	1,060	755	203.5
GG	10,000 - 3,000 . 400	880	1,175	805	204.2	770	1,075	785	197	800	1,210	885	206	880	1,140	840	223
GG	12,000 - 3,600 . 400	960	1,230	880	216.2	835	1,135	860	225	870	1,315	970	224	995	1,240	925	230
GG	14,000 - 4,200 . 400	1,040	1,300	950	235.5	905	1,175	930	252	945	1,355	1,130	237	1,065	1,295	1,000	258
GG	16,000 - 4,800 . 400	1,115	1,355	1,020	254.5	970	1,220	990	269	1,025	1,445	1,185	245	1,140	1,355	1,130	267
GG	18,000 - 5,400 . 400	1,180	1,410	1,075	267.5	1,040	1,280	1,055	273	1,085	1,450	1,285	267	1,230	1,430	1,185	272
GG	20,000 - 6,000 . 400	1,245	1,460	1,140	291.5	1,110	1,340	1,115	286	1,150	1,540	1,335	284	1,295	1,475	1,275	295
GG	24,000 - 7,200 . 400	1,365	1,540	1,255	316.5	1,270	1,485	1,245	286	1,255	1,610	1,400	329	1,430	1,585	1,335	322
GG	28,000 - 8,400 . 400	1,475	1,630	1,345	346.5	1,360	1,560	1,340	303	1,375	1,740	1,505	331	1,545	1,675	1,440	340
GG	30,000 - 9,000 . 400	1,545	1,680	1,410	347	1,415	1,605	1,400	325	1,425	1,750	1,530	352	1,585	1,705	1,465	367
GG	35,000 - 10,500 . 400	1,665	1,775	1,500	374.5	1,515	1,680	1,465	354	1,550	1,850	1,655	384	1,725	1,820	1,585	384
GG	45,000 - 13,500 . 400	1,900	1,935	1,700	424	1,730	1,850	1,665	404.5	1,785	2,090	1,875	419	1,960	1,995	1,795	436

Dimensions in mm

Bearings with larger loads or strokes, or with different bearing conditions, can be designed on request.

All of these bearings are designed with the following parameters:
 Rotation = 10 mrad
 Strength of concrete underneath bearing = min. 30 MPa
 Strength of concrete above bearing = min. 30 MPa

TETRON CD FX POT BEARINGS



Fixed pot bearings are made up of a pot, an elastomeric disc and a piston. The pot is fixed to the support and the piston is fixed to the superstructure.

This model does not allow any horizontal movement. It therefore transfers the loads from the superstructure to its support in all directions.

Bearings with horizontal load = 10% of vertical load

	EN			BS			AASHTO			AS		
	ΦA	ΦD	H	ΦA	ΦD	H	ΦA	ΦD	H	ΦA	ΦD	H
FX 500 - 50	160	160	54	155	155	54	180	180	59	155	155	54
FX 1,000 - 100	210	210	54	230	230	54	240	240	60	235	235	64
FX 1,500 - 150	275	275	68	280	280	63	280	280	65	300	300	68
FX 2,000 - 200	325	325	78	330	330	66	325	325	69	350	350	78
FX 3,000 - 300	405	405	82	410	410	67	410	410	81	430	430	82
FX 4,000 - 400	470	470	85	470	470	67	485	485	95	510	510	86
FX 5,000 - 500	525	525	98	530	530	70	550	550	112	575	575	90
FX 6,000 - 600	580	580	98	590	590	70	610	610	113	640	640	92
FX 8,000 - 800	675	675	113	685	685	76	715	715	141	730	730	110
FX 10,000 - 1,000	760	760	126	765	765	80	810	810	154	810	810	125
FX 12,000 - 1,200	825	825	140	825	825	98	895	895	162	885	885	138
FX 14,000 - 1,400	915	915	148	895	895	102	970	970	180	980	980	147
FX 16,000 - 1,600	985	985	150	970	970	106	1,045	1,045	180	1,040	1,040	151
FX 18,000 - 1,800	1,050	1,050	153	1,015	1,015	112	1,110	1,110	197	1,130	1,130	152
FX 20,000 - 2,000	1,110	1,110	161	1,070	1,070	119	1,175	1,175	213	1,190	1,190	160
FX 24,000 - 2,400	1,225	1,225	172	1,185	1,185	122	1,295	1,295	235	1,310	1,310	171
FX 28,000 - 2,800	1,315	1,315	192	1,265	1,265	138	1,395	1,395	263	1,410	1,410	186
FX 30,000 - 3,000	1,365	1,365	195	1,315	1,315	140	1,445	1,445	264	1,465	1,465	189
FX 35,000 - 3,500	1,490	1,490	211	1,430	1,430	142	1,560	1,560	286	1,575	1,575	210
FX 45,000 - 4,500	1,685	1,685	237	1,620	1,620	168	1,770	1,770	322	1,795	1,795	233

Dimensions in mm



Bearings with horizontal load = 30% of vertical load

	EN			BS			AASHTO			AS		
	ΦA	ΦD	H	ΦA	ΦD	H	ΦA	ΦD	H	ΦA	ΦD	H
FX 500 - 150	160	160	53	160	160	59	180	180	59	165	165	54
FX 1,000 - 300	220	220	60	235	235	59	250	250	60	255	255	54
FX 1,500 - 450	295	295	64	290	290	67	300	300	65	315	315	67
FX 2,000 - 600	350	350	72	335	335	68	345	345	69	375	375	71
FX 3,000 - 900	440	440	84	415	415	78	415	415	81	475	475	84
FX 4,000 - 1,200	525	525	92	480	480	87	480	480	94	560	560	92
FX 5,000 - 1,500	590	590	109	545	545	95	535	535	111	630	630	108
FX 6,000 - 1,800	660	660	110	590	590	108	595	595	114	705	705	116
FX 8,000 - 2,400	770	770	127	695	695	123	690	690	134	800	800	138
FX 10,000 - 3,000	870	870	145	765	765	142	775	775	161	905	905	152
FX 12,000 - 3,600	955	955	157	835	835	160	845	845	169	1,025	1,025	161
FX 14,000 - 4,200	1,050	1,050	167	905	905	178	920	920	187	1,100	1,100	175
FX 16,000 - 4,800	1,120	1,120	181	980	980	186	990	990	205	1,190	1,190	180
FX 18,000 - 5,400	1,200	1,200	186	1,030	1,030	194	1,075	1,075	206	1,275	1,275	194
FX 20,000 - 6,000	1,270	1,270	203	1,100	1,100	196	1,125	1,125	231	1,350	1,350	198
FX 24,000 - 7,200	1,400	1,400	210	1,245	1,245	197	1,250	1,250	257	1,485	1,485	215
FX 28,000 - 8,400	1,530	1,530	226	1,355	1,355	201	1,365	1,365	271	1,605	1,605	235
FX 30,000 - 9,000	1,590	1,590	239	1,415	1,415	204	1,415	1,415	291	1,665	1,665	238
FX 35,000 - 10,500	1,710	1,710	260	1,540	1,540	206	1,545	1,545	295	1,805	1,805	255
FX 45,000 - 13,500	1,955	1,955	282	1,800	1,800	209	1,780	1,780	340	2,045	2,045	283

Dimensions in mm

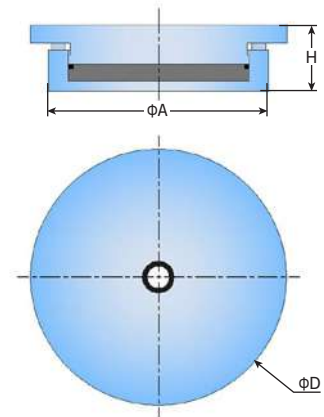

All of these bearings are designed with the following parameters:
 Rotation = 10 mrad
 Strength of concrete underneath bearing = min. 30 MPa
 Strength of concrete above bearing = min. 30 MPa

Bearings with larger loads or strokes, or with different bearing conditions, can be designed on request.

TETRON SB SPHERICAL BEARINGS

There are three types of bearing, distinguished by their movement capacity:

Type	Free sliding bearing	Guided sliding bearing	Fixed bearing
	GL	GGL/GGT	FX
Symbol			
Vertical load			
Rotation	 Up to 50 mrad	 Up to 50 mrad	 Up to 50 mrad
Movement Horizontal	 Multidirectional	 Unidirectional	 Blocked

Design basis

The structure of the bearings is designed on the basis of the following parameters:

- Vertical load;
- Acceptable movement;
- Acceptable rotation;
- Exposure temperatures;
- Acceptable stresses on the supports;
- Horizontal load.

The design can be produced in accordance with various standards, the most common of which are EN 1337 and AASHTO LRFD 2012.

Isoslide®, for compact, stronger bearings

Sliding surfaces conventionally formed by stainless steel/PTFE or chrome steel/PTFE contact accept limited stresses. Freyssinet therefore now offers a new material known as Isoslide® to replace the PTFE. Isoslide® accepts higher stresses, in most cases making it possible to reduce the bearing dimensions. The tables on the following pages show the two sliding material options available for TETRON SB bearings. Isoslide® is also five times more wear resistant than PTFE, which is particularly beneficial for applications involving frequent, repetitive movements.

Designation

The designation of TETRON SB bearings identifies their main characteristics.

GL Free sliding bearing	20,000 Vertical load at ULS in kN	• 250 Total acceptable longitudinal movement in mm	• 40 Total acceptable transverse movement in mm
GGT Transverse guided bearing		- 800 Vertical load at ULS in kN	• 40 Total acceptable transverse movement in mm
GGL Longitudinal guided bearing		- 800 Transverse load at ULS in kN	• 40 Total acceptable longitudinal movement in mm
FX Fixed bearing		- 900 Horizontal load at ULS in kN (resultant of x/y*)	

This gives the following designations, for example:

With PTFE

- TETRON SB GL 20,000.250.40
- TETRON SB GGL 20,000-800.40
- TETRON SB FX 20,000-900

With Isoslide®

- TETRON SB ISO GL 20,000.250.40
- TETRON SB ISO GGL 20,000-800.40
- TETRON SB ISO FX 20,000-900

*x: longitudinal axis
y: transverse axis

TETRON SB GL SPHERICAL BEARINGS



This free sliding spherical bearing is made up of a base plate, a chrome-plated spherical cap and a PTFE or Isoslide® plate, on which the upper plate can slide freely. The base plate is fixed to the support (pier, abutment, column, etc.) and the upper plate is fixed to the superstructure.

This model is designed to permit horizontal movements, without any resistance other than the internal friction.

Bearings with $\pm 50\text{mm}$ longitudinal and $\pm 20\text{mm}$ transverse movement

	PTFE								Isoslide®							
	EN				AASHTO				EN				AASHTO			
	ΦA	B	C	H	ΦA	B	C	H	ΦA	B	C	H	ΦA	B	C	H
GL 500 - 100 . 40	175	300	200	75	195	320	220	75	165	290	190	85	165	290	190	80
GL 1,000 - 100 . 40	220	350	250	85	250	380	280	80	170	290	200	90	170	290	200	90
GL 1,500 - 100 . 40	250	380	280	85	295	430	330	90	195	320	220	90	195	320	220	90
GL 2,000 - 100 . 40	280	420	320	95	330	470	370	90	215	340	240	90	215	340	240	90
GL 2,500 - 100 . 40	305	440	340	95	360	510	410	100	235	370	270	90	235	370	270	90
GL 3,000 - 100 . 40	330	470	370	100	385	530	430	105	250	380	280	100	255	380	280	95
GL 4,000 - 100 . 40	370	520	420	115	435	590	490	110	285	420	320	100	295	420	320	105
GL 5,000 - 100 . 40	420	570	470	120	480	640	540	110	320	460	370	105	330	450	360	105
GL 6,000 - 100 . 40	460	610	510	130	520	680	580	125	340	480	390	115	360	480	390	115
GL 8,000 - 100 . 40	540	690	590	135	590	760	660	140	400	530	450	120	415	530	450	120
GL 10,000 - 100 . 40	610	760	660	145	655	840	740	155	450	570	510	135	465	570	500	135
GL 12,000 - 100 . 40	675	820	720	155	710	900	800	155	500	610	550	145	510	610	540	140
GL 16,000 - 100 . 40	785	930	830	175	810	1,010	910	175	585	680	635	150	590	680	630	160
GL 20,000 - 100 . 40	880	1,030	930	190	895	1,100	1,000	190	660	740	710	165	660	740	700	170
GL 24,000 - 100 . 40	970	1,120	1,020	205	975	1,190	1,090	205	725	790	780	175	725	790	770	175
GL 28,000 - 100 . 40	1,055	1,200	1,100	225	1,045	1,270	1,170	210	790	850	840	195	775	850	830	195
GL 30,000 - 100 . 40	1,090	1,240	1,140	250	1,080	1,310	1,210	220	820	870	870	200	805	870	860	205
GL 35,000 - 100 . 40	1,180	1,330	1,230	250	1,165	1,410	1,310	240	890	940	940	200	875	940	940	215
GL 40,000 - 100 . 40	1,265	1,420	1,320	270	1,240	1,490	1,390	235	955	1,010	1,010	220	935	1,010	1,000	230
GL 45,000 - 100 . 40	1,345	1,500	1,400	275	1,310	1,570	1,470	255	1,015	1,070	1,070	220	995	1,070	1,060	250
GL 50,000 - 100 . 40	1,420	1,570	1,470	290	1,380	1,650	1,550	265	1,070	1,130	1,130	245	1,055	1,130	1,130	265

Dimensions in mm

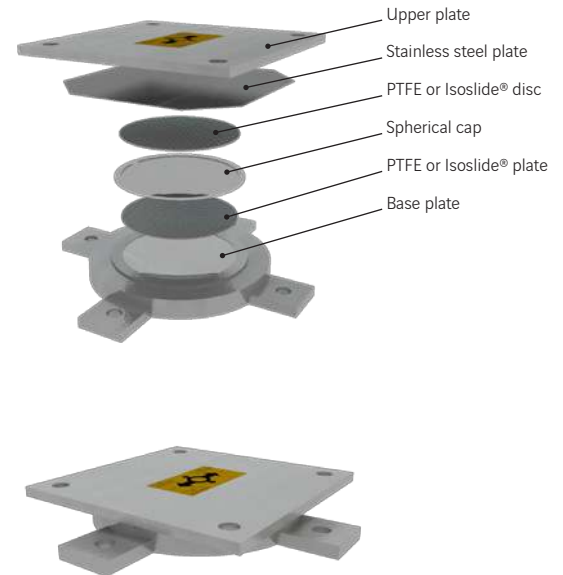

Bearings with $\pm 200\text{mm}$ longitudinal and $\pm 20\text{mm}$ transverse movement

	PTFE								Isoslide®							
	EN				AASHTO				EN				AASHTO			
	ΦA	B	C	H	ΦA	B	C	H	ΦA	B	C	H	ΦA	B	C	H
GL 500 - 400 . 40	175	600	200	85	195	620	220	75	165	590	190	95	165	590	190	85
GL 1,000 - 400 . 40	220	650	250	95	250	680	280	85	170	590	200	100	170	590	200	85
GL 1,500 - 400 . 40	250	680	280	95	295	730	330	90	195	620	220	100	195	620	220	90
GL 2,000 - 400 . 40	280	720	320	105	330	770	370	95	215	640	240	100	215	640	240	90
GL 2,500 - 400 . 40	305	740	340	105	360	810	410	100	235	670	270	100	235	670	270	90
GL 3,000 - 400 . 40	330	770	370	110	385	830	430	110	250	680	280	105	255	680	280	95
GL 4,000 - 400 . 40	370	820	420	120	435	890	490	115	280	720	320	105	295	720	320	105
GL 5,000 - 400 . 40	420	870	470	130	480	940	540	120	315	750	360	115	330	750	350	105
GL 6,000 - 400 . 40	460	910	510	135	520	980	580	135	340	780	390	120	360	780	385	115
GL 8,000 - 400 . 40	540	990	590	145	590	1,060	660	140	400	830	450	125	415	830	445	130
GL 10,000 - 400 . 40	610	1,060	660	155	655	1,140	740	150	450	870	505	135	465	870	500	145
GL 12,000 - 400 . 40	675	1,120	720	165	710	1,200	800	160	500	910	550	145	510	910	540	145
GL 16,000 - 400 . 40	785	1,230	830	185	810	1,310	910	175	585	980	635	150	590	980	630	160
GL 20,000 - 400 . 40	880	1,330	930	200	895	1,400	1,000	195	660	1,040	710	165	660	1,040	700	170
GL 24,000 - 400 . 40	970	1,420	1,020	220	975	1,490	1,090	195	725	1,090	780	175	725	1,090	770	175
GL 28,000 - 400 . 40	1,055	1,500	1,100	235	1,045	1,570	1,170	210	790	1,150	840	195	775	1,150	830	195
GL 30,000 - 400 . 40	1,090	1,540	1,140	255	1,080	1,610	1,210	225	820	1,170	870	200	805	1,170	860	205
GL 35,000 - 400 . 40	1,180	1,630	1,230	260	1,165	1,710	1,310	225	890	1,240	940	200	875	1,240	925	225
GL 40,000 - 400 . 40	1,265	1,720	1,320	275	1,240	1,790	1,390	240	955	1,310	1,010	220	935	1,310	990	240
GL 45,000 - 400 . 40	1,345	1,800	1,400	285	1,310	1,870	1,470	260	1,015	1,370	1,070	220	995	1,370	1,050	240
GL 50,000 - 400 . 40	1,420	1,870	1,470	290	1,380	1,950	1,550	270	1,070	1,430	1,130	235	1,055	1,430	1,105	245

Dimensions in mm

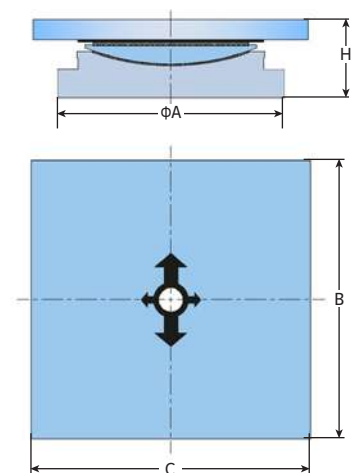

The PTFE versions of the bearings above are designed with the following parameters:

Rotation = 30 mrad
Strength of concrete underneath bearing = min. 30 MPa
Strength of concrete above bearing = min. 30 MPa

The Isoslide® versions of the bearings above are designed with the following parameters:

Rotation = 30 mrad
Strength of concrete underneath bearing = min. 50 MPa
Strength of concrete above bearing = min. 50 MPa

Bearings with larger loads or strokes, or with different bearing conditions, can be designed on request.



TETRON SB GG SPHERICAL BEARINGS

The spherical bearing is designed like a free sliding bearing, but with a guide. The guide is generally secure to the upper sliding plate, and abuts against the edges of the base plate.

This bearing model accepts horizontal movement along the axis of the guide and horizontal loads in the perpendicular direction.

Bearings with horizontal load = 10% of vertical load and ±50mm movement



	PTFE										Isoslide®									
	EN					AASHTO					EN					AASHTO				
	A	a	B	C	H	A	a	B	C	H	A	a	B	C	H	A	a	B	C	H
GG 500 - 50 - 100	175	185	300	315	110	195	204	320	335	110	165	165	280	295	115	165	170	280	300	120
GG 1,000 - 100 - 100	220	240	350	370	115	250	274	380	405	115	170	180	290	310	120	170	175	290	305	120
GG 1,500 - 150 - 100	250	275	380	415	125	295	334	430	475	120	195	205	330	345	125	195	204	320	345	120
GG 2,000 - 200 - 100	280	310	420	450	125	330	374	470	525	140	215	235	340	385	125	215	239	340	390	125
GG 2,500 - 250 - 100	305	345	440	495	130	360	414	510	575	140	235	260	370	410	130	235	269	370	420	130
GG 3,000 - 300 - 100	330	380	470	540	135	385	444	530	615	140	250	275	380	435	135	255	274	380	435	135
GG 4,000 - 400 - 100	380	425	520	595	145	445	504	590	675	145	285	305	410	475	135	295	304	410	485	140
GG 5,000 - 500 - 100	430	470	560	640	155	480	559	640	740	150	315	345	440	515	150	330	344	440	515	140
GG 6,000 - 600 - 100	475	510	590	690	160	520	609	680	790	160	350	365	470	545	155	360	369	470	550	145
GG 8,000 - 800 - 100	555	595	670	775	180	590	694	760	895	170	410	415	530	585	155	415	419	530	600	155
GG 10,000 - 1,000 - 100	625	655	720	845	185	650	769	830	960	175	470	465	620	655	170	470	464	620	655	165
GG 12,000 - 1,200 - 100	690	715	780	905	185	710	844	900	1,045	195	570	515	720	705	185	560	514	710	705	185
GG 16,000 - 1,600 - 100	805	815	870	1,035	215	810	964	1,010	1,185	220	600	600	720	820	210	590	589	720	810	195
GG 20,000 - 2,000 - 100	905	915	960	1,135	230	895	1,069	1,100	1,300	235	700	675	850	895	215	700	659	850	880	205
GG 24,000 - 2,400 - 100	995	1,020	1,050	1,250	245	975	1,169	1,190	1,400	240	810	745	950	980	235	800	719	950	970	235
GG 28,000 - 2,800 - 100	1,075	1,110	1,140	1,350	260	1,050	1,264	1,280	1,505	245	810	810	950	1,070	245	800	779	950	1,030	235
GG 30,000 - 3,000 - 100	1,115	1,140	1,170	1,400	270	1,085	1,289	1,310	1,560	260	850	840	1,000	1,100	260	850	809	1,000	1,070	250
GG 35,000 - 3,500 - 100	1,210	1,240	1,270	1,500	275	1,175	1,399	1,410	1,660	265	990	910	1,140	1,170	270	990	879	1,140	1,140	260
GG 40,000 - 4,000 - 100	1,300	1,340	1,350	1,630	290	1,260	1,494	1,490	1,775	290	1,000	975	1,150	1,265	275	1,000	944	1,150	1,245	275
GG 45,000 - 4,500 - 100	1,400	1,440	1,440	1,740	315	1,340	1,579	1,570	1,880	305	1,070	1,035	1,220	1,335	295	1,060	1,004	1,210	1,305	285
GG 50,000 - 5,000 - 100	1,455	1,520	1,510	1,830	320	1,410	1,669	1,650	1,980	320	1,170	1,095	1,320	1,405	310	1,170	1,059	1,320	1,370	310

Dimensions in mm

Bearings with horizontal load = 30% of vertical load and ±200mm movement

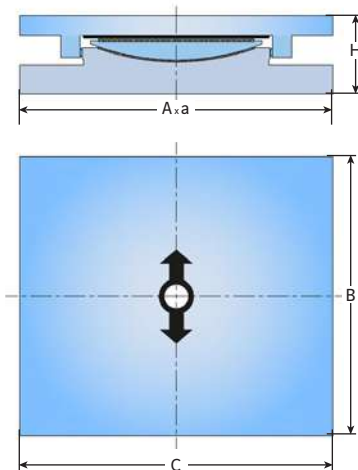

	PTFE										Isoslide®									
	EN					AASHTO					EN					AASHTO				
	A	a	B	C	H	A	a	B	C	H	A	a	B	C	H	A	a	B	C	H
GG 500 - 150 . 400	175	185	600	315	125	195	204	620	335	125	165	165	590	325	130	165	169	590	310	135
GG 1,000 - 300 . 400	220	240	650	390	135	250	274	680	425	130	170	185	600	345	135	170	179	600	340	135
GG 1,500 - 450 . 400	250	275	680	425	135	295	334	730	485	140	210	205	660	365	135	210	209	660	370	135
GG 2,000 - 600 . 400	290	310	730	470	140	330	374	770	535	150	280	235	730	395	140	280	239	730	400	135
GG 2,500 - 750 . 400	360	345	810	505	145	360	414	810	585	160	350	260	800	420	145	350	269	800	440	150
GG 3,000 - 900 . 400	420	380	870	560	155	440	444	890	625	160	420	275	870	455	155	425	274	870	445	150
GG 4,000 - 1,200 . 400	490	430	940	680	170	510	504	950	685	175	500	310	950	500	165	480	309	930	490	165
GG 5,000 - 1,500 . 400	530	470	980	680	180	530	559	980	770	180	530	355	980	565	185	555	344	980	545	175
GG 6,000 - 1,800 . 400	630	510	1,080	720	185	630	609	1,080	820	185	630	390	1,080	600	185	665	369	1,080	580	175
GG 8,000 - 2,400 . 400	750	590	1,200	820	210	850	694	1,300	905	205	850	450	1,300	660	200	850	434	1,290	645	190
GG 10,000 - 3,000 . 400	840	670	1,290	900	220	900	759	1,350	990	220	850	505	1,300	745	210	850	489	1,300	730	215
GG 12,000 - 3,600 . 400	1,010	740	1,460	980	235	1,010	834	1,460	1,085	240	850	565	1,300	815	240	850	544	1,300	795	240
GG 16,000 - 4,800 . 400	1,130	860	1,580	1,120	265	1,120	954	1,570	1,215	270	1,120	660	1,570	920	270	1,140	639	1,570	900	270
GG 20,000 - 6,000 . 400	1,210	970	1,660	1,270	290	1,210	1,049	1,660	1,350	295	1,200	740	1,650	1,060	295	1,200	714	1,650	1,025	295
GG 24,000 - 7,200 . 400	1,280	1,060	1,730	1,380	315	1,280	1,149	1,730	1,480	320	1,300	805	1,750	1,135	300	1,300	779	1,750	1,110	295
GG 28,000 - 8,400 . 400	1,370	1,160	1,820	1,520	340	1,360	1,234	1,810	1,585	325	1,320	880	1,770	1,230	320	1,320	844	1,770	1,195	320
GG 30,000 - 9,000 . 400	1,400	1,190	1,850	1,550	340	1,405	1,269	1,850	1,630	350	1,400	900	1,850	1,250	320	1,400	874	1,850	1,225	320
GG 35,000 - 10,500 . 400	1,510	1,290	1,960	1,670	365	1,520	1,379	1,960	1,760	375	1,510	980	1,960	1,350	345	1,510	944	1,960	1,315	350
GG 40,000 - 12,000 . 400	1,750	1,380	2,220	1,790	395	1,570	1,464	2,000	1,865	400	1,570	1,050	2,020	1,460	375	1,570	1,014	2,020	1,425	375
GG 45,000 - 13,500 . 400	1,750	1,470	2,200	1,880	395	1,775	1,554	2,200	1,965	405	1,620	1,120	2,070	1,560	400	1,620	1,079	2,070	1,530	405
GG 50,000 - 15,000 . 400	1,920	1,570	2,370	1,990	420	1,790	1,644	2,210	2,075	435	1,750	1,180	2,200	1,620	405	1,750	1,139	2,200	1,580	420

Dimensions in mm

Bearings with larger loads or strokes, or with different bearing conditions, can be designed on request.

The PTFE versions of the bearings above are designed with the following parameters:

Rotation = 30 mrad
Strength of concrete underneath bearing = min. 30 MPa
Strength of concrete above bearing = min. 30 MPa

The Isoslide® versions of the bearings above are designed with the following parameters:

Rotation = 30 mrad
Strength of concrete underneath bearing = min. 50 MPa
Strength of concrete above bearing = min. 50 MPa

TETRON SB FX SPHERICAL BEARINGS



Fixed spherical bearings are made up of a base plate, a chrome-plated spherical cap, a PTFE or Isoslide® plate and an upper plate. The base plate is fixed to the support and the upper plate is fixed to the superstructure.

This model does not allow any horizontal movement. It therefore transfers the loads from the superstructure to its support in all directions.

Bearings with horizontal load = 10% of vertical load

	PTFE						Isoslide®					
	EN			AASHTO			EN			AASHTO		
	ΦA	ΦD	H	ΦA	ΦD	H	ΦA	ΦD	H	ΦA	ΦD	H
FX 500 - 50	225	225	85	235	235	95	225	225	90	215	215	95
FX 1,000 - 100	275	275	95	305	305	95	235	235	90	230	230	105
FX 1,500 - 150	310	310	100	355	355	105	260	260	100	265	265	105
FX 2,000 - 200	335	335	110	395	395	115	275	275	105	285	285	105
FX 2,500 - 250	370	370	120	440	440	125	290	290	120	315	315	105
FX 3,000 - 300	405	405	125	470	470	125	310	310	120	335	335	125
FX 4,000 - 400	450	450	140	530	530	140	355	355	130	370	370	140
FX 5,000 - 500	505	505	150	585	585	150	385	385	145	410	410	140
FX 6,000 - 600	565	565	150	635	635	165	420	420	145	440	440	140
FX 8,000 - 800	635	635	170	730	730	190	485	485	160	500	500	165
FX 10,000 - 1,000	710	710	190	815	815	200	540	540	170	550	550	165
FX 12,000 - 1,200	775	775	200	890	890	215	590	590	175	595	595	175
FX 16,000 - 1,600	910	910	215	1,030	1,030	240	680	680	195	680	680	210
FX 20,000 - 2,000	1,000	1,000	240	1,145	1,145	245	760	760	220	750	750	220
FX 24,000 - 2,400	1,100	1,100	255	1,245	1,245	270	835	835	240	835	835	235
FX 28,000 - 2,800	1,185	1,185	275	1,350	1,350	295	900	900	250	910	910	255
FX 30,000 - 3,000	1,225	1,225	280	1,395	1,395	295	935	935	250	925	925	265
FX 35,000 - 3,500	1,320	1,320	295	1,500	1,500	320	1,000	1,000	270	1,000	1,000	280
FX 40,000 - 4,000	1,415	1,415	315	1,610	1,610	350	1,075	1,075	285	1,065	1,065	305
FX 45,000 - 4,500	1,500	1,500	350	1,705	1,705	365	1,135	1,135	305	1,130	1,130	315
FX 50,000 - 5,000	1,580	1,580	350	1,805	1,805	380	1,195	1,195	310	1,185	1,185	330

Dimensions in mm

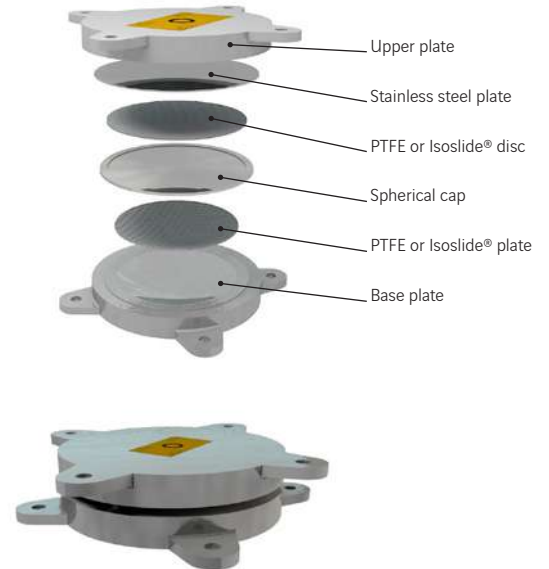

Bearings with horizontal load = 30% of vertical load

	PTFE						Isoslide®					
	EN			AASHTO			EN			AASHTO		
	ΦA	ΦD	H	ΦA	ΦD	H	ΦA	ΦD	H	ΦA	ΦD	H
FX 500 - 150	225	225	100	255	255	95	235	235	95	230	230	95
FX 1,000 - 300	285	285	120	330	330	115	255	255	110	255	255	125
FX 1,500 - 450	345	345	135	380	380	130	270	270	125	295	295	135
FX 2,000 - 600	395	395	150	430	430	130	310	310	140	320	320	140
FX 2,500 - 750	435	435	160	480	480	150	340	340	140	350	350	140
FX 3,000 - 900	475	475	165	515	515	155	370	370	150	380	380	155
FX 4,000 - 1,200	540	540	175	580	580	170	420	420	155	420	420	165
FX 5,000 - 1,500	605	605	195	640	640	175	465	465	180	465	465	175
FX 6,000 - 1,800	665	665	205	695	695	200	510	510	180	500	500	190
FX 8,000 - 2,400	765	765	220	800	800	220	580	580	190	565	565	205
FX 10,000 - 3,000	855	855	245	895	895	235	650	650	215	630	630	230
FX 12,000 - 3,600	930	930	270	980	980	255	705	705	235	683	683	245
FX 16,000 - 4,800	1,070	1,070	285	1,130	1,130	295	860	860	270	785	785	275
FX 20,000 - 6,000	1,195	1,195	320	1,260	1,260	310	920	920	295	910	910	310
FX 24,000 - 7,200	1,315	1,315	355	1,375	1,375	345	985	985	320	980	980	320
FX 28,000 - 8,400	1,420	1,420	375	1,485	1,485	370	1,090	1,090	335	1,050	1,050	360
FX 30,000 - 9,000	1,475	1,475	375	1,540	1,540	375	1,105	1,105	365	1,085	1,085	375
FX 35,000 - 10,500	1,590	1,590	415	1,655	1,655	405	1,190	1,190	400	1,190	1,190	405
FX 40,000 - 12,000	1,695	1,695	450	1,770	1,770	425	1,325	1,325	410	1,285	1,285	430
FX 45,000 - 13,500	1,790	1,790	480	1,875	1,875	460	1,420	1,420	435	1,365	1,365	455
FX 50,000 - 15,000	1,910	1,910	480	1,985	1,985	465	1,670	1,670	450	1,440	1,440	480

Dimensions in mm

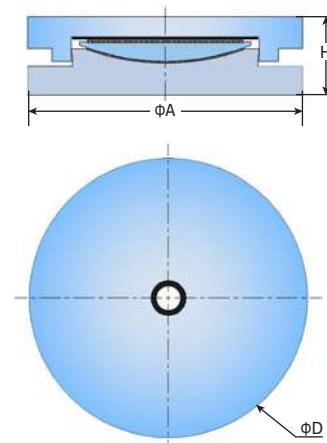

The PTFE versions of the bearings above are designed with the following parameters:

Rotation = 30 mrad
Strength of concrete underneath bearing = min. 30 MPa
Strength of concrete above bearing = min. 30 MPa

The Isoslide® versions of the bearings above are designed with the following parameters:

Rotation = 30 mrad
Strength of concrete underneath bearing = min. 50 MPa
Strength of concrete above bearing = min. 50 MPa

Bearings with larger loads or strokes, or with different bearing conditions, can be designed on request.

SPECIAL BEARINGS

Special bearings are used to meet specific movement or load constraints.

They do not contain any elastomeric components and the load is generally transferred by contact between metal parts.

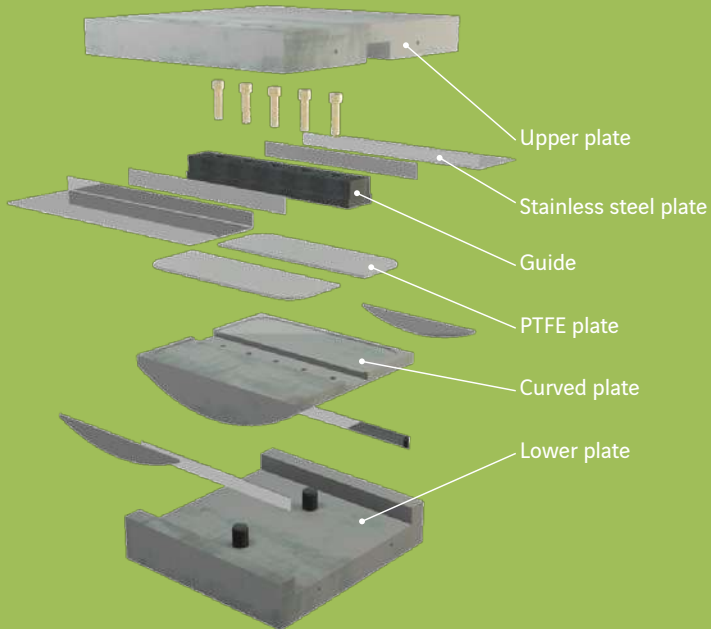

Oscillating linear bearings

The oscillating linear bearing is made up of a lower metal plate on which a rocker oscillates. Shear pins hold the rocker in place. Like pot or spherical bearings, oscillating linear bearings can be fixed, free sliding or guided sliding.

The specific feature of this bearing is that it only permits rotation in one direction.

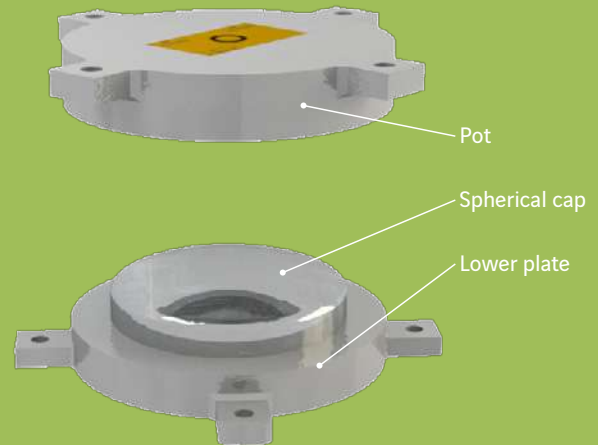

Pad bearings

A pad bearing is a bearing with a single rocker. The technology is the same as a pot bearing, in which the elastomeric cushion is replaced by contact between a spherical surface and a flat surface to enable rotation.

Like all bearings, pad bearings are available in fixed, free sliding or guided sliding versions.



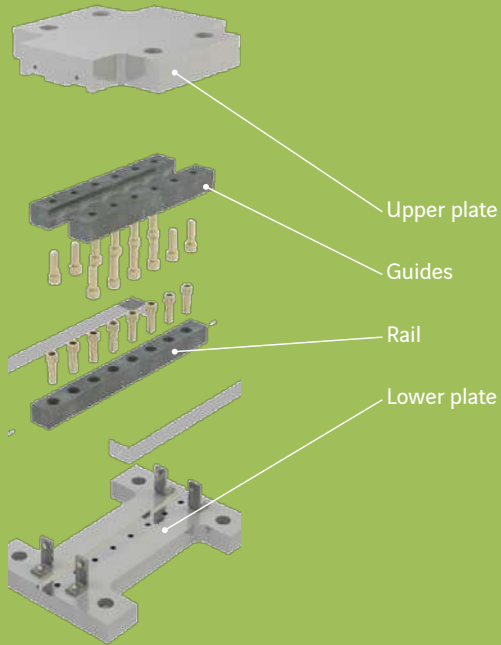

Shear key

The shear key is made up of a lower plate fitted with a rail and an upper plate fitted with two guides.

It is designed to accept horizontal movement along the axis of the rail and to transfer perpendicular horizontal loads. It does not take up any vertical load.

The shear key is generally combined with free sliding bearings positioned on either side of it.

It makes it possible to separate the "guiding" function from the bearings, which is generally necessary with very large horizontal loads.

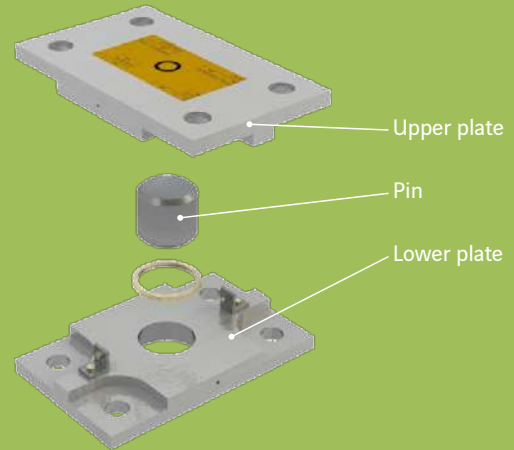
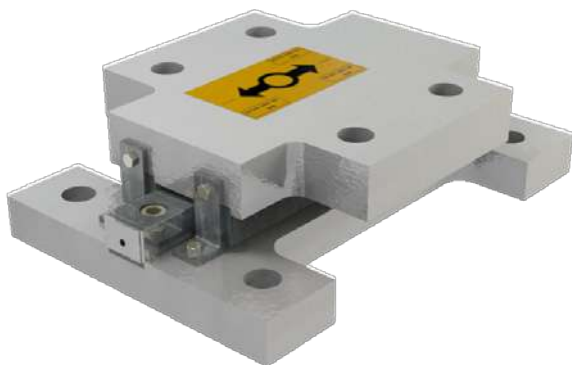

Shear pin

The shear pin is made up of a lower plate and an upper plate connected to each other by a rod known as a pin. The pin accepts rotations about its axis, and transfers large horizontal loads. It does not take up any vertical load.

Like the shear key, it is generally combined with free sliding bearings.



OPTIONS

Freyssinet offers a number of options on its bearings. They meet a variety of requirements, such as:

- reducing the space occupied;
- adapting to structures;
- simplifying installation methods or structural monitoring.



BTZ railway line, Algeria

Anti-uplift system

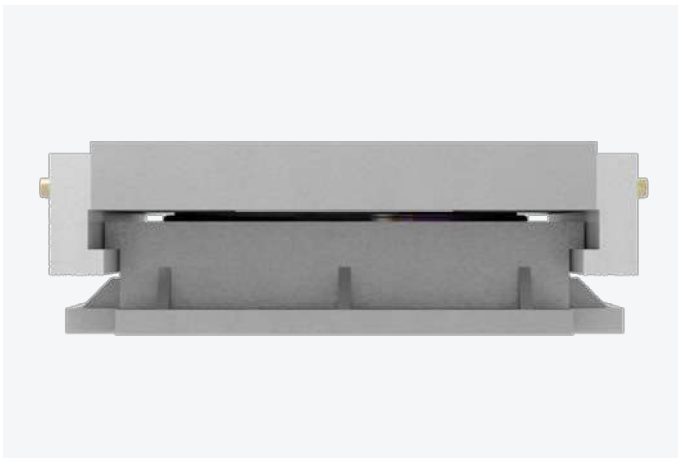

The anti-uplift system is used to withstand an occasional or permanent vertical uplift force on the superstructure. It is made up of lateral restraint guides or a central rod. One of these solutions is chosen depending on the forces applied, the space available and the type of bearing. The system must be used in conjunction with anchoring to the structure in accordance with the forces applied. Bearings with an anti-uplift system are often found on roofs, pedestrian footbridges or bridges subject to earthquakes.

Temporary stop



The temporary bearing blocks the translational movement of a sliding bearing during the construction phase. This system is made up of lateral stops or adjustable wedges fastened underneath the sliding plate.



Successful projects: Kallang Stadium – Singapore/Loukkos and El Hachef Viaducts – Morocco

Successful projects: Lusail CP4 – Doha, Qatar /Szajol Railway Bridge – Szolnok, Hungary

Shear stop

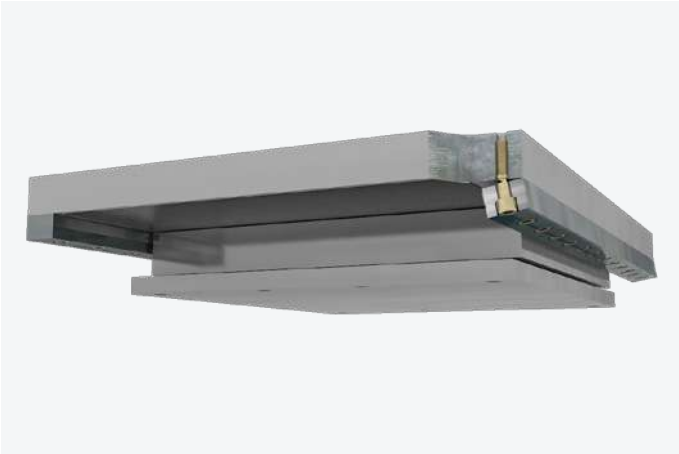

The principle behind the shear stop is that it blocks the movement of the bearing up to a given load, and then releases it when that load is exceeded. The bearing guide is fastened with specially designed shear screws. This technique is used to limit the seismic forces on structures.

Successful projects: Ilettes Bridge - France/BTZ railway line - Algeria

Incremental launching bearing



The incremental launching bearing is specially designed for use first as a slide chair during the incremental launching, or sliding of a bridge deck, and then as a permanent bearing during the service life of the structure. This technique makes it possible to install the bearings before the deck is put in place, and avoids the installation of a temporary slide chair that must then be replaced with permanent bearings. The bearing is temporarily secured with screws and stops that block movement. The bearing is able to rotate during the launching phase, giving complete contact between the sliding pads and the underside of the deck.

Successful projects: Gerringong Bridge - Australia/Gala Bridge - Portugal

Jacking bearing



This system can be used to raise the superstructure by acting directly on the bearing. For pot bearings, a fluid (paste, resin, etc.) is injected into the pot, underneath the elastomeric disc. For elastomeric bearings, a Freyssinet flat jack is positioned underneath the elastomeric block.

The jacking bearing is used during both construction and repair (load transfer to the bearing), or when the superstructure support is at risk of subsidence (unstable soil, etc.).

Successful projects: Eiffel Tower - Paris, France/Cavalcavia Bridge - Switzerland

Instrumentation



Pot bearings can be fitted with a vertical load measuring system. Readings are taken directly on the bearing, or on a remote unit with a wired or radio connection.

This system enables the structure's operator to monitor the behaviour of the structure over time.

Successful projects: SEA Dordogne Viaduct - France/Eiffel Tower - Paris, France

OPTIONS

Spirit level

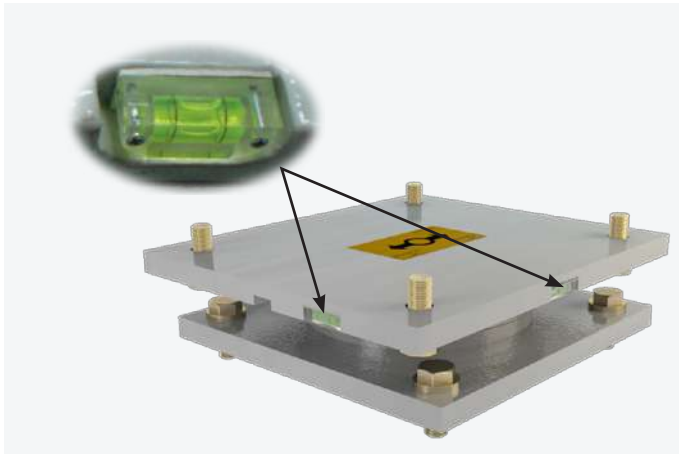

The spirit level (required by EN 1337) can be fitted to all types of bearing. It enables the operator installing the bearings to ensure that they are completely horizontal, thus facilitating the installation. It also makes it possible to observe any rotation during the service life of the structure.

Protective skirts

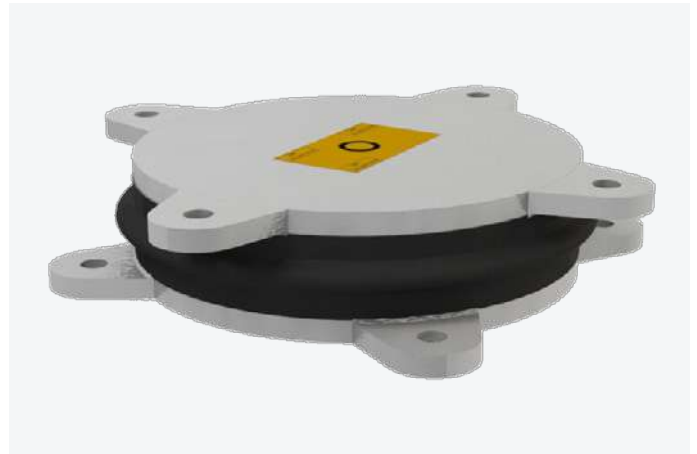

Protective skirts can be installed around the bearing in order to protect the sliding surfaces from dirt. This equipment is particularly useful in areas subject to sandstorms or for bearings that might be temporarily submerged.

Presetting



The position of the sliding plates in sliding bearings can be adjusted to allow for irreversible movements such as shrinkage and creep. This option makes it possible to reduce the dimensions of the sliding plates.

Corrosion protection

As structural components, bearings must be protected against corrosion. There are several methods:

Stainless steel:

The use of stainless steel is a particularly effective solution to avoid any corrosion problems.

Surface treatment:

Any treatment system can be used. The system is selected depending on the surroundings and reference standard applied.

If no standard is specified, Freyssinet offers reliable, extensively tested systems.

System	Description	Use
C4 ANV ACQPA	230 µm in three coats: two epoxy coats + one polyurethane coat	Highly corrosive atmosphere
C4 ZNV ACQPA	Metal spraying + 140 µm in two coats: one epoxy coat + one polyurethane coat	Highly corrosive atmosphere
C5 Ma ANV ACQPA	280 µm in four coats: one zinc ethyl silicate coat + two epoxy coats + one polyurethane coat	Extremely corrosive atmosphere (marine)
C5 Ma ZNV ACQPA	Metal spraying + 200 µm in three coats: two epoxy coats + one polyurethane coat	Extremely corrosive atmosphere (marine)
S1C	Metal spraying + 270 µm in four coats: three epoxy coats + one polyurethane coat	Extremely corrosive atmosphere (marine)

FASTENING SYSTEMS

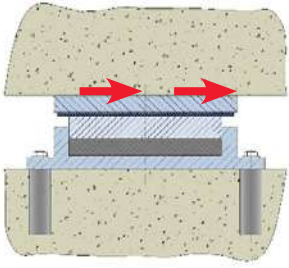

Friction

Horizontal loads are transferred between the superstructure and the bearing by contact between the two surfaces. The design takes into account the vertical load and the friction coefficient of the contact zone. This system does not withstand uplift force.

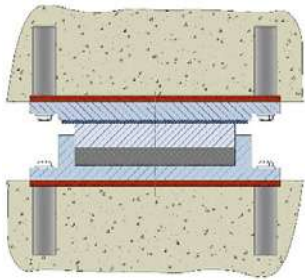

Distribution plate

Distribution plates (generally embedded in the concrete) can be inserted between the structure and the bearing. They make it easier to remove the bearing, and in some cases make it possible to reduce the bearing dimensions.

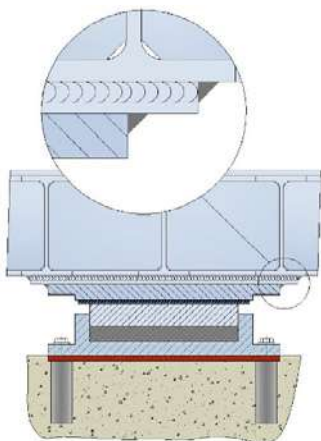

Welding

In some cases (for example on incrementally launched bridges), the precise location of the bearing relative to the structure is not known in advance. The solution of welding the bearing to the superstructure (metal deck) or to an embedded distribution plate (concrete deck) is then implemented. Special measures are taken to protect the weld from corrosion.

Anchors

Anchors are used to secure the bearing to the structure for significant vertical and/or horizontal loads.

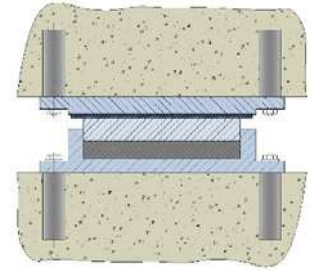

Bolts

Bolts are generally used for fastening to a metal structure; these are designed to withstand any tensile stress and the horizontal load.

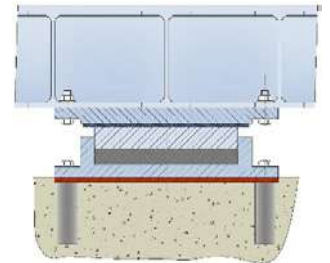

The different types of anchor



Welded studs



Dowel bushing



Dowel bushing with collar

BEARING PRODUCTION

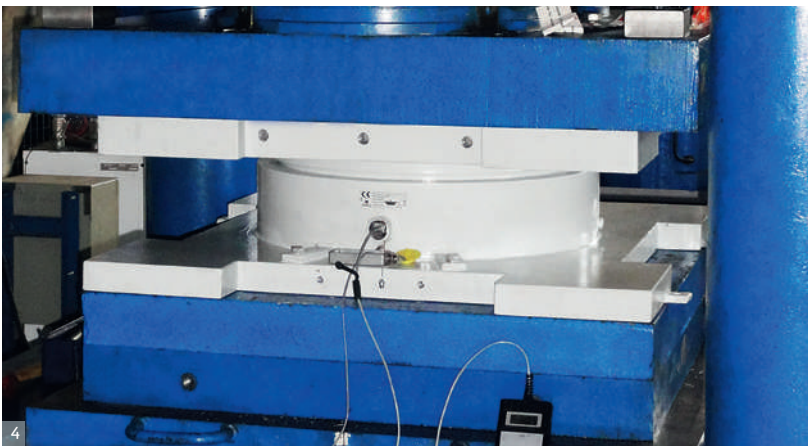
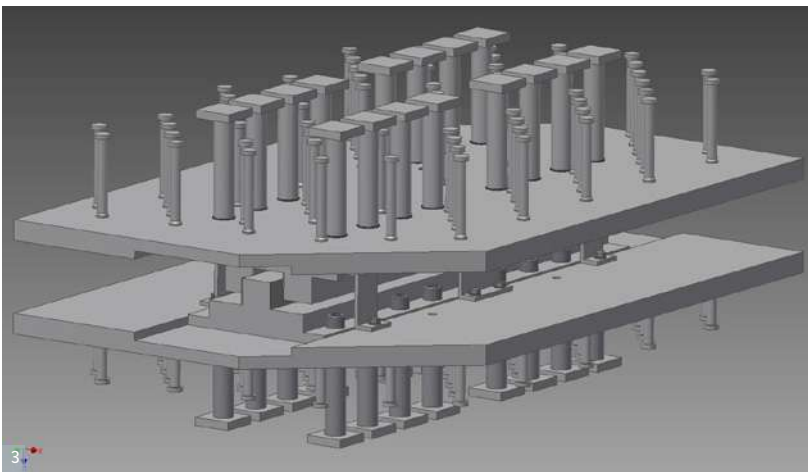
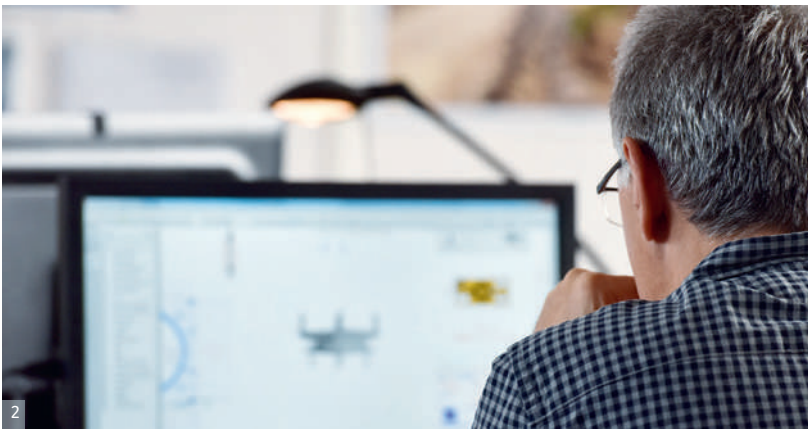
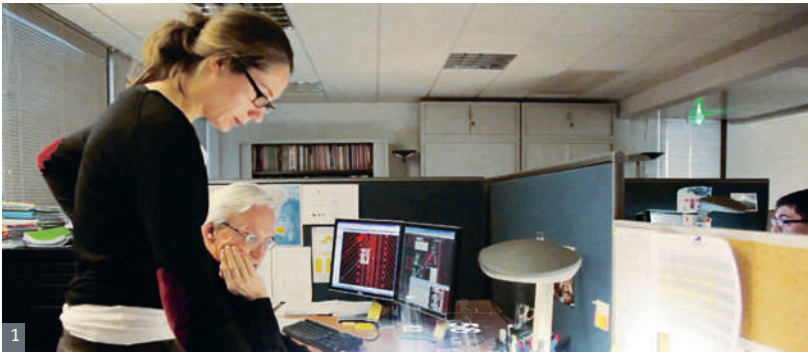

Freyssinet designs and produces all of the bearings supplied to its customers at its own plants, meaning that it can ensure the same quality of production and service for all, worldwide.

This complete control over its products and systems enables Freyssinet to adapt its solutions to a wide range of applications, including in extreme operating conditions.

Products designed and developed by Freyssinet

All of Freyssinet's bearings are developed and designed by an in-house technical department that ensures compliance with applicable standards and project specifications. Coordination between the design, manufacturing solutions and the choice of materials is critical for optimising solutions and offering reliable, durable products.

Certified products

Recognition of Freyssinet's expertise and high-quality processes is reflected in a number of certifications in a wide range of fields. In addition to the European certification represented by CE marking, Freyssinet bearings are approved or recognised in a number of countries on all five continents.

Expertise and industrial know-how

Based in France, the industrial division of FPC (Freyssinet Products Company) acts as a focal point for all of Freyssinet's expertise in materials, manufacturing, production engineering, control and logistics. It coordinates all of Freyssinet's production activities worldwide. A team of experts in smelting, elastomers, mechanical engineering and quality travel the length and breadth of the five continents, defining and inspecting manufacturing processes and ensuring the same level of product quality, irrespective of the production location.

Guaranteed quality

The vast network of FPC-managed production sites requires daily involvement from the quality control department, which guarantees the quality and conformity of the products supplied. All products are checked by FPC using its cutting-edge measuring instruments.

All checkpoints are defined internally, and FPC issues a certificate of conformity for each product supplied.



5



6



7



8



9

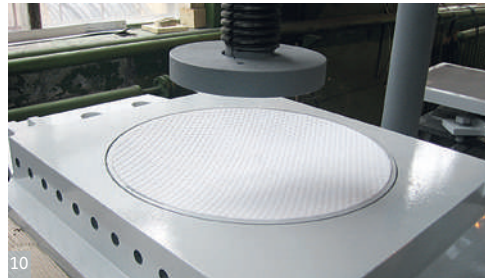

10

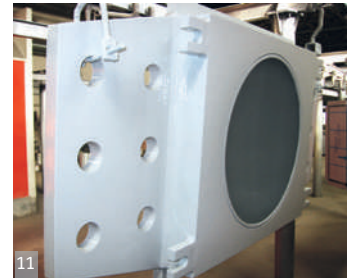

11



12

1. Design office
2. Design firm
3. 3D modelling
4. Instrumented bearing test
5. The FPC building
6. Pot bearing in the showroom

7. Quality control on a pot bearing
8. Inspection
9. Pot bearing in the showroom
10. Assembly of a spherical bearing
11. Surface treatment
12. Instrumented bearing

SUCCESSFUL PROJECTS



Nudo Sur Bridge on the M-30
Spain



Gerringong Bridge
Australia



Hassan II Bridge
Rabat, Morocco



Hans Wilsdorf Bridge
Geneva, Switzerland



Third Istanbul Bypass
Turkey



Stade de France
Paris, France



Stanford American International School
United States



Ronda de Malaga
Spain



Musées de Confluences
Lyon, France



SEA - Tours-Bordeaux high-speed railway line - Boème Viaduct
France



Over 60 locations worldwide

AMERICAS . Argentina . Brazil . Canada . Chile . Colombia . United States . Mexico . Panama . El Salvador . Venezuela .
EUROPE . Belgium . Bulgaria . Denmark . Spain . Estonia . France . Hungary . Ireland . Iceland . Latvia . Lithuania . Luxembourg . Macedonia . Norway .
Netherlands . Poland . Portugal . Czech Republic . Romania . United Kingdom . Russia . Serbia . Slovenia . Sweden . Switzerland . Turkey .
AFRICA AND MIDDLE EAST . Abu Dhabi . South Africa . Algeria . Saudi Arabia . Dubai . Egypt . Jordan . Kuwait . Morocco . Oman .
Qatar . Sharjah . Tunisia . ASIA . South Korea . Hong Kong . India . Indonesia . Japan . Macau . Malaysia . Pakistan . Philippines . Singapore .
Thailand . Taiwan . Vietnam . OCEANIA . Australia . New Zealand



FREYSSINET
SUSTAINABLE TECHNOLOGY



www.freyssinet.com

Follow us on:

